



Filter Inductors, Toroid, Radial Leaded



FEATURES

- Choice of encapsulated (TE) or dipped (TD) styles
- TD style combines low cost with excellent performance in commercial applications
- High Q and wide selection of Q vs. frequency ranges in one small package. Large number of standard inductance values
- Material categorization: for definitions of compliance please see www.vishay.com/doc?99912



RoHS COMPLIANT

STANDARD ELECTRICAL SPECIFICATIONS (applies to core only)								
MODEL			TC CODE	TEMPERATURE COEFFICIENT	TEMPERATURE RANGE	TC AVAILABILITY		
TE-3 TD-3	TE-4 TD-4	TE-5 TD-5				Q0	Q3	Q4
X	X	X	TA	0 % ± 1 %	-55 °C to +125 °C		X	X
X	X	X	TD	0 % ± 0.1 %	0 °C to +55 °C		X	X
X	X	X	TL ⁽¹⁾	+40 ppm/°C to + 110 ppm/°C +85 ppm/°C to + 185 ppm/°C	-55 °C to +25 °C +25 °C to +85 °C			X
X	X	X	TM	0 ± 0.25 %	-65 °C to +125 °C		X	X
X	X	X	TR	50 ppm/°C (typical)	-65 °C to +125 °C	X		
X	X	X	TW	0 % ± 0.25 %	-55 °C to +85 °C		X	X

Note

⁽¹⁾ Inverse of typical temperature coefficient of polystyrene capacitor.

INDUCTANCE RANGE			
TC CODE	TE-3 TD-3	TE-4 TD-4	TE-5 TD-5
Q0	50 µH to 15 mH	150 µH to 20 mH	1 mH to 100 mH
Q3	500 µH to 487 mH	1 mH to 2 H	5 mH to 2 H
Q4	1 mH to 1 H	2 mH to 5 H	10 mH to 5 H

ELECTRICAL SPECIFICATIONS

Tolerance:

TE-3, TD-3 = ± 1 % > 2 mH, ± 2 % 154 µH to 2 mH, ± 5 % < 150 µH

TE-4, TD-4 = ± 1 % > 2 mH, ± 2 % < 2 mH

TE-5, TD-5 = ± 1 % > 2 mH, ± 2 % < 2 mH

Insulation resistance: 1000 MΩ minimum

Dielectric strength: 1000 V minimum (TE)

500 V minimum (TD)

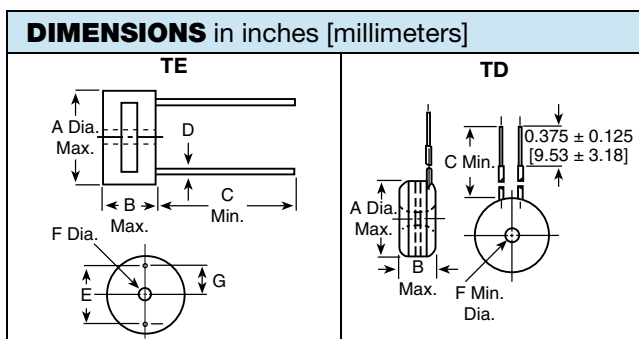

MODEL	A	B	C	D	E	F	G
TE-3	0.685 [17.40]	0.385 [9.78]	1.0 [25.40]	0.025 [0.635]	0.500 [12.70]	0.093 [2.36]	0.250 [6.35]
TD-3	0.685 [17.40]	0.320 [8.13]	3.0 [76.20]	-	-	0.125 [3.18]	-
TE-4	1.06 [26.92]	0.500 [12.70]	1.0 [25.40]	0.032 [0.813]	0.900 [22.86]	0.120 [3.05]	0.450 [11.43]
TD-4	1.06 [26.92]	0.437 [11.10]	4.0 [101.60]	-	-	0.220 [5.59]	-
TE-5	1.33 [33.78]	0.735 [18.67]	1.0 [25.40]	0.032 [0.813]	1.0 [25.40]	0.144 [3.66]	0.500 [12.70]
TD-5	1.32 [33.53]	0.688 [17.48]	6.0 [152.40]	-	-	0.220 [5.59]	-

MECHANICAL SPECIFICATIONS

Terminal strength: 2 pounds pull test (TE)

Vibration: per MIL-T-27 (TE)

Shock: per MIL-T-27 (TE)

Weight:

TE-3 = 5.1 g, TD-3 = 4.9 g typical

TE-4 = 20 g, TD-4 = 17 g typical

TE-5 = 53 g, TD-5 = 52 g typical

MATERIAL SPECIFICATIONS

Coating: vinyl (TD), non-flammable, abrasion and moisture resistant. Resists most cleaning agents (consult factory for chemicals which may be used)

Standard terminals: tinned copper (TE), stranded, tinned copper, teflon insulated (TD)

Encapsulant: epoxy (TE)

Gauge:

TE-3 = 22 AWG, TD-3 = 26 AWG

TE-4 = 20 AWG, TD-4 = 24 AWG

TE-5 = 20 AWG, TD-5 = 24 AWG



ORDERING INFORMATION						
TE-3	Q0	TR	5 mH	± 1 %	EB	e2
MODEL	Q TYPE	TC CODE	INDUCTANCE VALUE	INDUCTANCE TOLERANCE	PACKAGE CODE	JEDEC® LEAD (Pb)-FREE STANDARD

GLOBAL PART NUMBER													
T	E	3	Q	0	T	R	E	B	5	0	0	1	F
MODEL			Q TYPE		TC CODE		PACKAGE CODE		INDUCTANCE VALUE				TOL.

DC RESISTANCE AND SELF-RESONANT FREQUENCIES (typical values)							
MODEL	IND. (µH)	DCR (Ω)			SRF (MHz)		
		Q0	Q3	Q4	Q0	Q3	Q4
TE-3, TD-3	50.0	0.68	-	-	7.6	-	-
TE-3, TD-3	100.0	1.0	-	-	5.1	-	-
TE-3, TD-3	332.0	3.3	-	-	2.9	-	-
TE-3, TD-3	1000.0	6.9	1.5	0.82	1.4	1.1	1.0
TE-3, TD-3	3320	24.0	4.1	2.3	0.79	0.57	0.55
TE-3, TD-3	10 000	84.0	14.0	5.9	0.40	0.29	0.25
TE-3, TD-3	15 000	106.0	17.0	9.1	0.34	0.24	0.21
TE-3, TD-3	33 200	-	40.0	18.0	-	0.14	0.12
TE-3, TD-3	100 000	-	138.0	58.0	-	0.08	0.077
TE-3, TD-3	332 000	-	555.0	220.0	-	0.04	0.038
TE-3, TD-3	1 000 000	-	-	670.0	-	-	0.019
TE-4, TD-4	150.0	0.54	-	-	2.6	-	-
TE-4, TD-4	1000	2.8	0.7	-	1.0	0.75	-
TE-4, TD-4	2000	5.5	1.4	0.78	0.64	0.54	0.45
TE-4, TD-4	10 000	27.0	4.9	2.5	0.24	0.21	0.18
TE-4, TD-4	20 000	54.0	9.6	5.0	0.18	0.15	0.13
TE-4, TD-4	100 000	-	56.0	23.0	-	0.059	0.051
TE-4, TD-4	1 000 000	-	570.0	260.0	-	0.016	0.014
TE-4, TD-4	2 000 000	-	1200.0	520.0	-	0.013	0.011
TE-5, TD-5	1000	1.8	-	-	0.80	-	-
TE-5, TD-5	3320	5.2	-	-	0.44	-	-
TE-5, TD-5	5000	6.5	1.8	-	0.33	0.32	-
TE-5, TD-5	10 000	13.0	2.4	1.7	0.21	0.20	0.15
TE-5, TD-5	33 200	49.0	8.8	3.9	0.12	0.11	0.086
TE-5, TD-5	100 000	133.0	27.0	11.0	0.061	0.057	0.044
TE-5, TD-5	332 000	-	80.0	44.0	-	0.032	0.024
TE-5, TD-5	1 000 000	-	222.0	121.0	-	0.016	0.012
TE-5, TD-5	2 000 000	-	475.0	217.0	-	0.012	0.008

STANDARD INDUCTANCE VALUE														
The following standardization chart is offered for your design and ordering convenience. Each value listed is within one percent of the preceding and succeeding values shown. All decade multiples of these values, within the range shown for each model in the chart, are Vishay Dale standard values. (Example: for a TE-3, 200 µH, 20 mH and 200 mH are all decade multiples of 2.00 and are all standard values.)	1.00	1.21	1.47	1.78	2.15	2.61	3.09	3.74	4.42	5.23	6.19	7.32	8.66	
	1.02	1.24	1.50	1.82	2.21	2.67	3.16	3.83	4.53	5.36	6.34	7.50	8.87	
	1.05	1.27	1.54	1.87	2.26	2.74	3.24	3.92	4.64	5.49	6.49	7.68	9.00	
	1.07	1.30	1.58	1.91	2.32	2.80	3.32	4.00	4.75	5.62	6.65	7.87	9.09	
	1.10	1.33	1.62	1.96	2.37	2.87	3.40	4.02	4.87	5.76	6.81	8.00	9.31	
	1.13	1.37	1.65	2.00	2.43	2.94	3.48	4.12	4.99	5.90	6.98	8.06	9.53	
	1.15	1.40	1.69	2.05	2.49	3.00	3.57	4.22	5.00	6.00	7.00	8.25	9.76	
	1.18	1.43	1.74	2.10	2.55	3.01	3.65	4.32	5.11	6.04	7.15	8.45		



PERFORMANCE GRAPHS: INDUCTANCE VS. DC BIAS, INDUCTANCE VS. AC EXCITATION

TE-3, TD-3

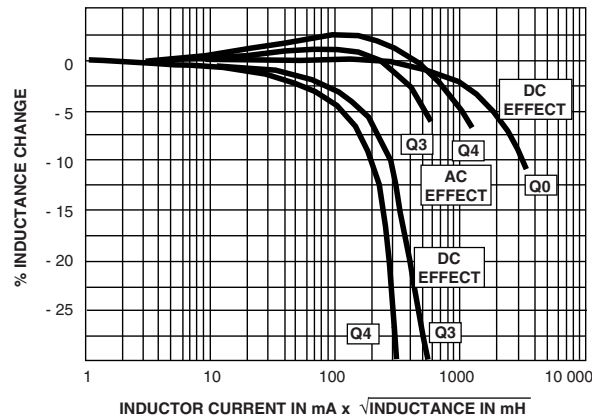

TE-4, TD-4

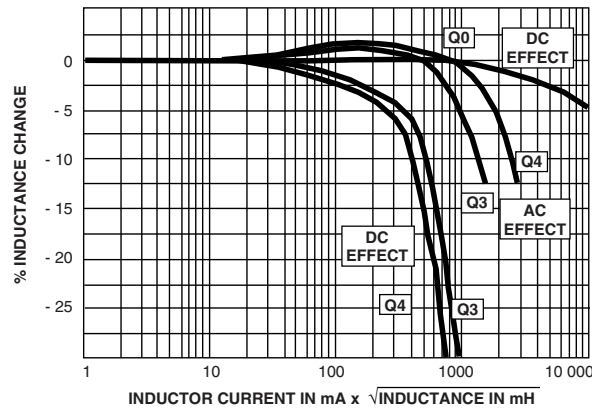

TE-5, TD-5

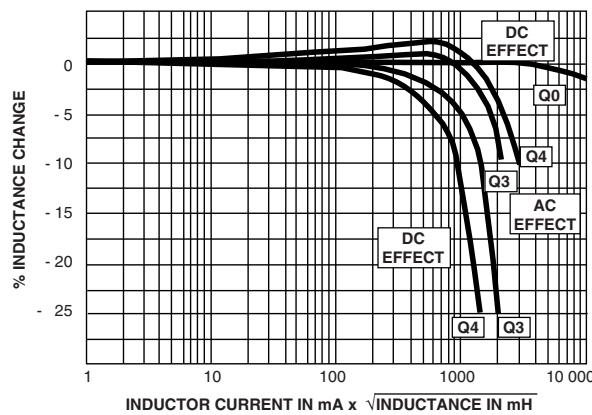



PERFORMANCE GRAPHS: TYPICAL Q VS. FREQUENCY

TE-3, TD-3

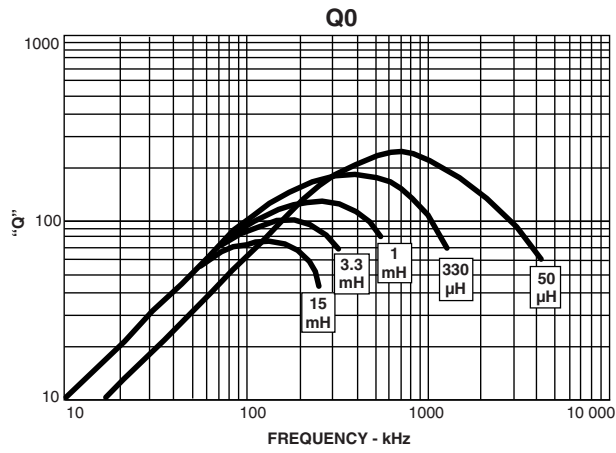

TE-4, TD-4

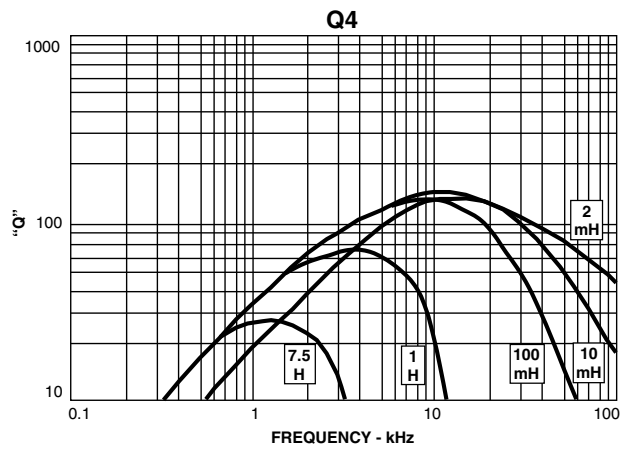
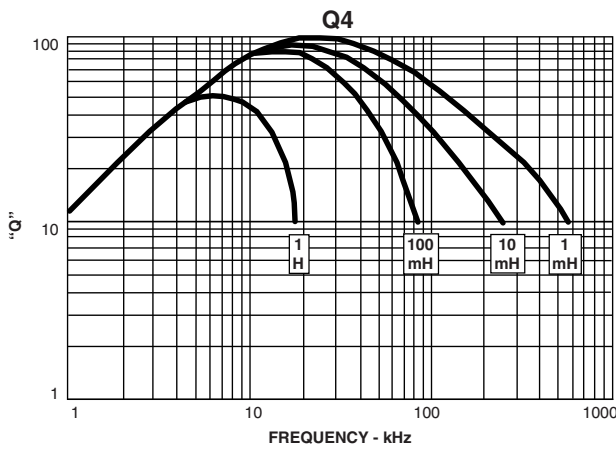
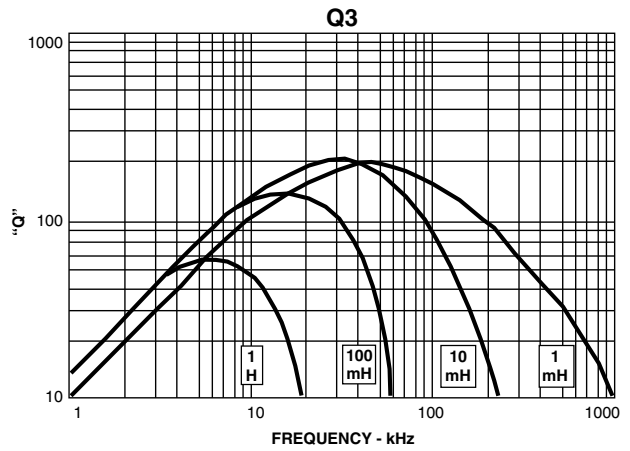
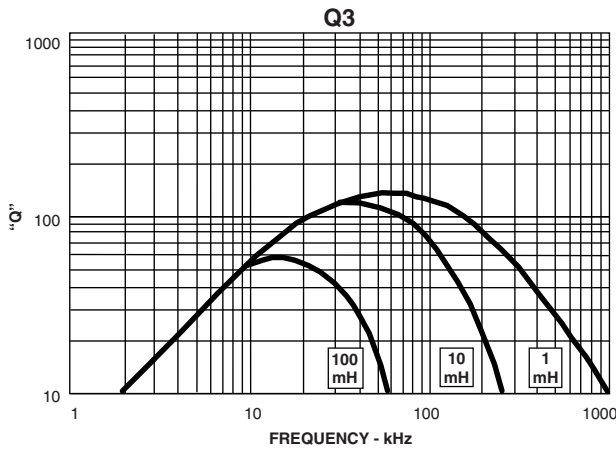
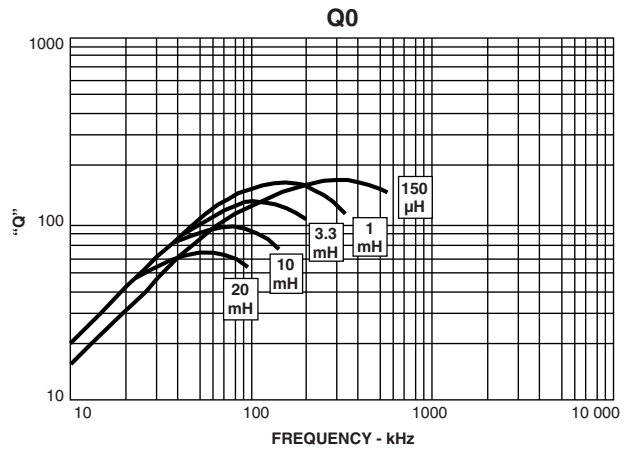



PERFORMANCE GRAPHS: TYPICAL Q VS. FREQUENCY

TE-5, TD-5

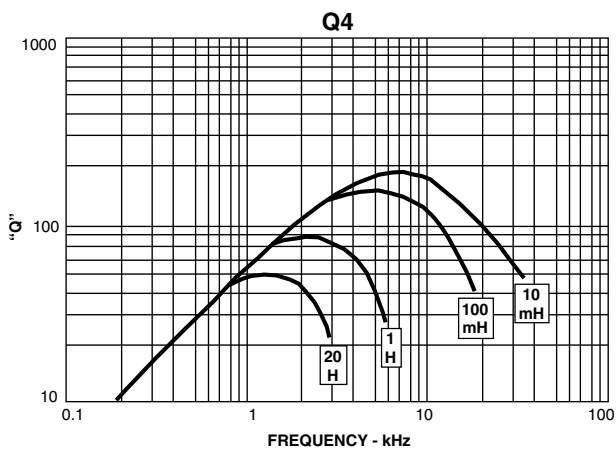
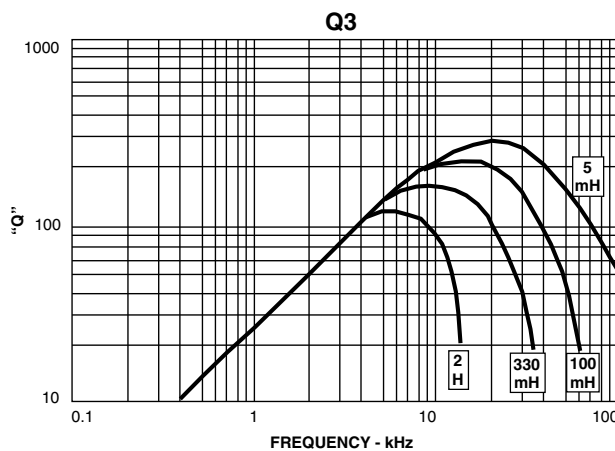
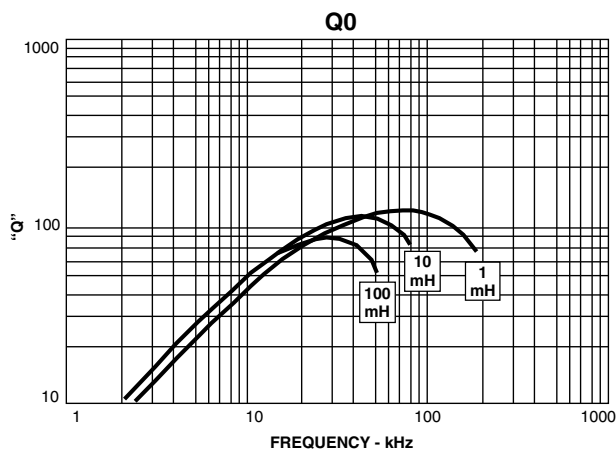

MARKING

- Vishay Dale
- Model
- Q type
- TC code
- Inductance value
- Inductance tolerance
- Date code



Disclaimer

ALL PRODUCT, PRODUCT SPECIFICATIONS AND DATA ARE SUBJECT TO CHANGE WITHOUT NOTICE TO IMPROVE RELIABILITY, FUNCTION OR DESIGN OR OTHERWISE.

Vishay Intertechnology, Inc., its affiliates, agents, and employees, and all persons acting on its or their behalf (collectively, "Vishay"), disclaim any and all liability for any errors, inaccuracies or incompleteness contained in any datasheet or in any other disclosure relating to any product.

Vishay makes no warranty, representation or guarantee regarding the suitability of the products for any particular purpose or the continuing production of any product. To the maximum extent permitted by applicable law, Vishay disclaims (i) any and all liability arising out of the application or use of any product, (ii) any and all liability, including without limitation special, consequential or incidental damages, and (iii) any and all implied warranties, including warranties of fitness for particular purpose, non-infringement and merchantability.

Statements regarding the suitability of products for certain types of applications are based on Vishay's knowledge of typical requirements that are often placed on Vishay products in generic applications. Such statements are not binding statements about the suitability of products for a particular application. It is the customer's responsibility to validate that a particular product with the properties described in the product specification is suitable for use in a particular application. Parameters provided in datasheets and / or specifications may vary in different applications and performance may vary over time. All operating parameters, including typical parameters, must be validated for each customer application by the customer's technical experts. Product specifications do not expand or otherwise modify Vishay's terms and conditions of purchase, including but not limited to the warranty expressed therein.

Except as expressly indicated in writing, Vishay products are not designed for use in medical, life-saving, or life-sustaining applications or for any other application in which the failure of the Vishay product could result in personal injury or death. Customers using or selling Vishay products not expressly indicated for use in such applications do so at their own risk. Please contact authorized Vishay personnel to obtain written terms and conditions regarding products designed for such applications.

No license, express or implied, by estoppel or otherwise, to any intellectual property rights is granted by this document or by any conduct of Vishay. Product names and markings noted herein may be trademarks of their respective owners.