

# BUZZERS TRANSDUCERS

STANDARD-Series

SMA-Series

SMAT-Series

SMB-Series



# KEY QUESTIONS FOR BUZZER DETERMINATION

## 1. Mounting method: panel ? wall ? PCB ?

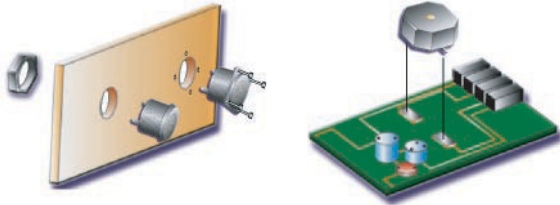

## 2. Connection method: wires ? pins (= through hole) ? fast-on ? SMD?



## 3. Maximum dimensions (in mm): diameter x height

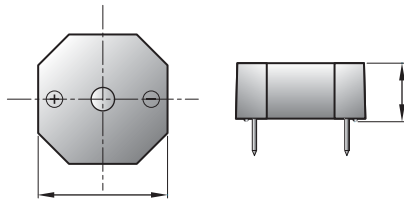

## 4. Pin distance (in mm)

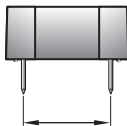

## 5. Supply voltage: DC for buzzers or AC for transducers



## 6. SPL – dB(A) @ 12Vdc, @ 30 cm or 1 meter

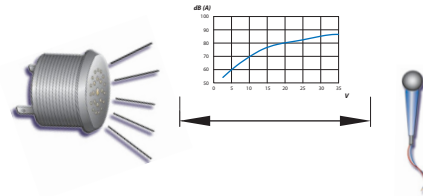

## 7. Sound frequency in Hz

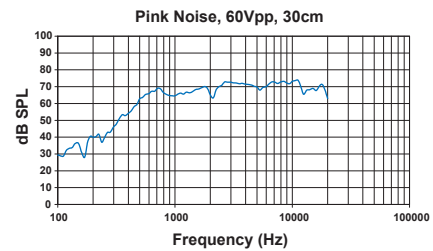

## 8. Current consumption in mA

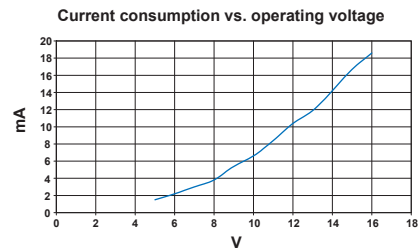

## 9. Temperature range in °C

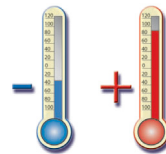

## 10. Life time

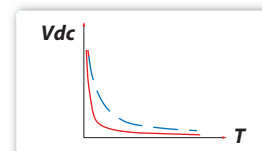

## STANDARD SERIES



Since 1977, Sonitron continuously invested in research and development, optimising their standard series which are used today under the most extreme and difficult environmental circumstances, by clients such as the Nato, Airbus, Volvo Penta, Dräger, Knogo,...

During the last 30 years, the standard series have proved to be the prime alarm, giving your equipment an added value. Several thousands of clients all over the world have chosen for the reliability and the excellent quality of piezoceramic buzzers of Sonitron.

These series are strongly recommended in applications that are critical and life time in continuous function is tested. Critical applications are life support systems and equipment used to warn for life danger such as: portable gas detectors, medical monitoring equipment, aircraft cockpit alarm's, car breaking alarm's etc...

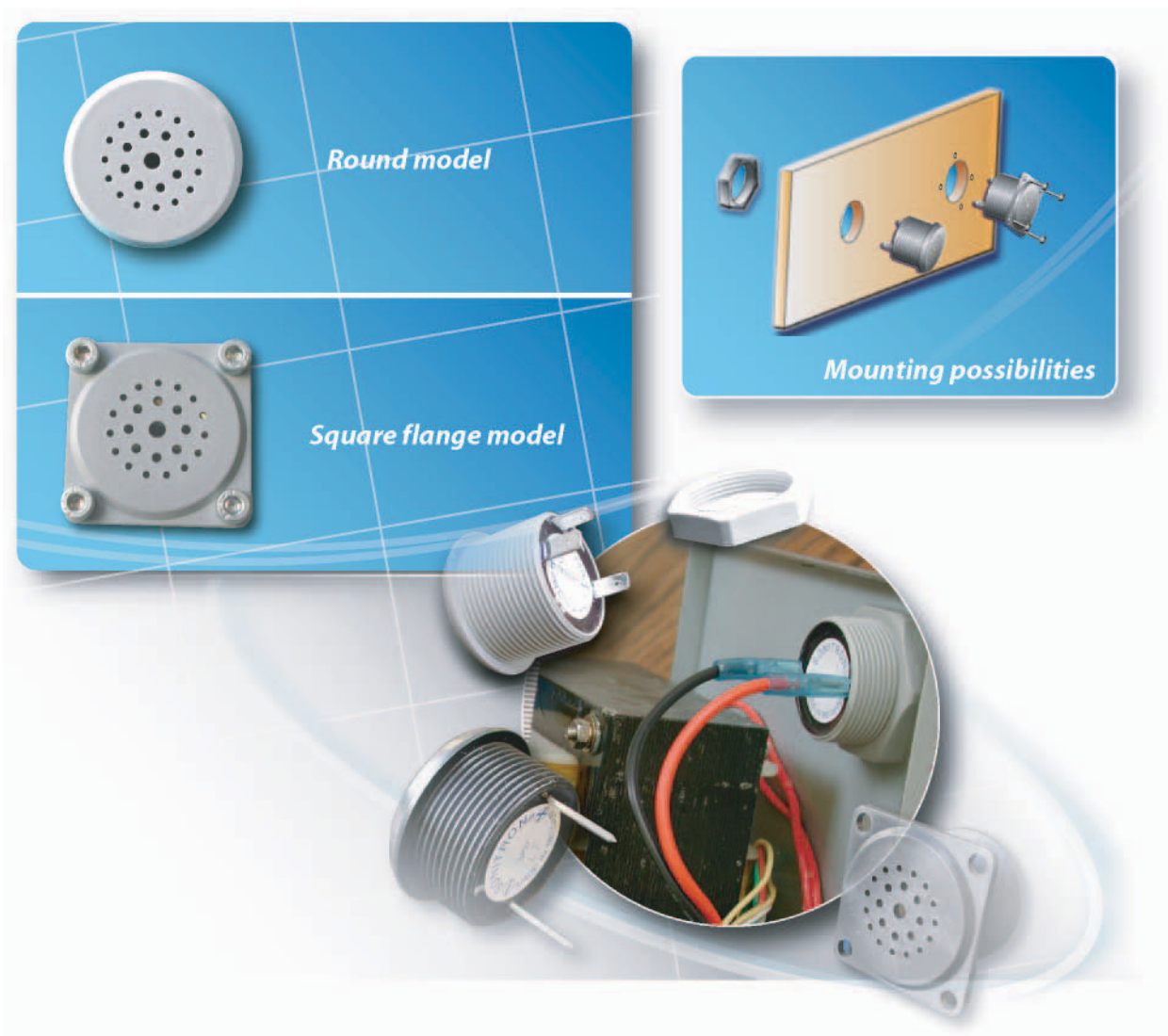

## INTRODUCTION

---



The standard series are based on the highest piezo technology and are considered as most robust series for industrial applications. The standard buzzers use a special shaped membrane (curved edge), which is fixed and glued into the housing. They are shock proof, as well as dust and waterproof (IP67). The different standard models cover a wide range of applications, offering functions such as continuous, intermittent, sweep and warbler, with a sound output of more than 100 dB(A).

All standard buzzers are available with various mounting methods, such as PCB or panel mounting and therefore

are equipped with either pins or fast-on terminals. The standard series include military models, extra loud types, as well as models operating at very low voltage consumption (SC 0715 BL at 0.7V) and very low current (SP27 = 4,8 mA at 9V).

## ADVANTAGES

---

- Extremely high sound pressure level with a very clear and penetrating sound output
- Solid state shock proof buzzer
- Dust and waterproof, rated to IP67
- PCB and panel mounting; pin or fast-on terminals
- Very high reliability
- Low power consumption
- Wide operating supply range
- Wide temperature range
- Electronics potted in epoxy
- Small in dimensions

## APPLICATIONS

---

- Alarms
- Agricultural equipment
- Monitoring and test equipment
- Medical equipment
- Military equipment
- Trucks & automobiles
- Boats & airplanes
- Signalling & process control equipment
- Fire detectors
- Vending-machine
- Cockpit alarm
- Surveyance equipment
- Underground
- Traffic control
- Industrial washing machine



## SPECIFICATIONS

\*All measurements are made @ 1 meter @ 12 Vdc in free air @21°C.

Model	Function	Operating Voltage **		Frequency ± 15% (Hz)	Pulse rate (Hz)	Operating Current (mA)		SPL (dB(A))*
		min. Vdc	max. Vdc			@ V min.	@ V max.	
SC 235 A	contin.	2	35	2500	-	0.3	8.6	73
SC 235 B	contin.	2	35	3500	-	0.4	8.4	87
SCI 535 A1	multif.	5	35	2500	1	1.4	12.5	77
SCI 535 B1	multif.	5	35	3500	1	1.4	12.2	86
SCI 535 A5	multif.	5	35	2500	5	1.4	12.5	77
SCI 535 B5	multif.	5	35	3500	5	1.4	12.2	86
SCR 535 A	multif.	5	35	2500	20	1.4	12.6	82
SCR 535 B	multif.	5	35	3500	20	1.4	12.6	84
SW 535 B	warbler	5	35	3500	-	1.3	10.6	87
SUC 516 A	contin.	5	16	2500	-	1.8	13.3	92
SUC 516 B	contin.	5	16	3500	-	0.8	13.0	90
SULC 516 B	contin.	5	16	3500	-	2.0	13.3	97
SULI 516 B1	intermit.	5	16	3500	1	1.2	11.6	94
SULI 516 B5	intermit.	5	16	3500	5	1.2	11.6	94
SUM 516 A1	multif.	5	16	2500	1	1.8	11.6	93
SUM 516 A5	multif.	5	16	2500	5	1.8	11.6	93
SULM 516 B1	multif.	5	16	3500	1	2.4	14.2	96
SULM 516 B5	multif.	5	16	3500	5	2.4	14.2	96
SC 0715 BL	contin.	0.7	15	3500	-	0.3	13.4	98

Operating temperature	-40°C to +85°C
Storage temperature	-40°C to +85°C
Life time (at 21°C)	@12Vdc continuous use min. 2000 hours (expected life time curve in addendum)
Case material	ABS (UL rating: 94 HB)
Standard colour of case	Grey
Terminal material	Tinned brass for both pin terminals and fast-on terminals
Supplemental	Reverse voltage protected. Weight: 13g to 24g

## SPECIALS

SP7	contin.	0.7	15	3500	-	0.3	13.4	71
SP27	contin.	3.5	9	3500	-	1.6	4.8	94(9V)
SCI 535 1700	multif.	5	35	1700	1	1.4	12.2	67

Operating temperature	-40°C to +85°C
Storage temperature	-40°C to +85°C
Life time (at 21°C)	@12Vdc continuous use min. 2000 hours (expected life time curve in addendum)
Case material	ABS (UL rating: 94 HB)
Standard colour of case	Grey (except the SP27 which is black)
Terminal material	Tinned brass for both pin terminals and fast-on terminals
Supplemental	Reverse voltage protected, except the SP27. Weight: 13g to 24g

Please note: objects in proximity of the buzzer cause reflections thereby the SPL can be increased or decreased.

## MULTI-FUNCTIONALITY OF THE STANDARD SERIES

The standard series offer the client several functions in one single buzzer. The selection of a function is illustrated in the scheme below.

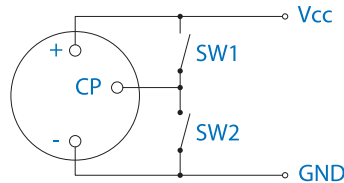

SW1	SW2	SCI 535	SUM 516	SULM 516	SCR 535
open	open	intermittent			cricket
closed	open	stop			stop
open	closed	continuous			continuous

## SELECTION GUIDE

The selection of an acoustic signal can be complex. That is why we present below our standard models with their most appropriate application.

SC 235 A SCI 535 A1/A5	General purpose buzzer with medium sound output for soft alarm in industrial and military applications where a high reliability is requested. These buzzers can be used in a wide supply voltage range.
SC 235 B SCI 535 B1/B5	General purpose buzzer with high sound output for low power consumption. Ideally suitable for alarm and industrial sound signals. These models combine high performances and great reliability. Today, the SC 235 B is considered as the most popular type.
SW 535 B SCR 535 A/B	A warbler or cricket tone with a special sound effect for warning and alerting devices.
SC 0715 BL	Special loud buzzer that functions at very low voltage (0.7 Vdc), going up to 15 Vdc, producing 98 dB(A) @ 1 meter @ 12Vdc. Wide range of applications, including battery powered alarms.
SUM 516 A1/A5	A universal buzzer type with a selection mode of three functions: continuous, intermittent or stop. High sound output for low power consumption and low supply voltages. This type can be used for multiple applications where a soft signal is required and a high reliability is a must.
SULM 516 B1/B5 SULC 516 B SUC 516 A/B SULI 516 B1/B5	A universal buzzer with a selection mode of different functions: continuous, intermittent or stop. High sound output at very low power consumption. It can be used in all alarm and warning signals where performance, power consumption and size are important. The SULI and the SUC models are simplified versions of the SULM 516 B5 that can be used when mode control is not required.
SP 7	The SP7 Buzzer has a closed front to withstand high water pressure. It is extremely waterproof and used in extreme depth under water applications. Standard delivered with gasket (O-ring). 
SP 27	Small sized buzzer to be used in applications where space is limited. Max. supply voltage is 9 Vdc. See also information in addendum.
SCI 535 1700	A buzzer for applications where a low frequency is required.

**ELECTRICAL PARAMETERS**

**Current consumption vs. operating voltage**

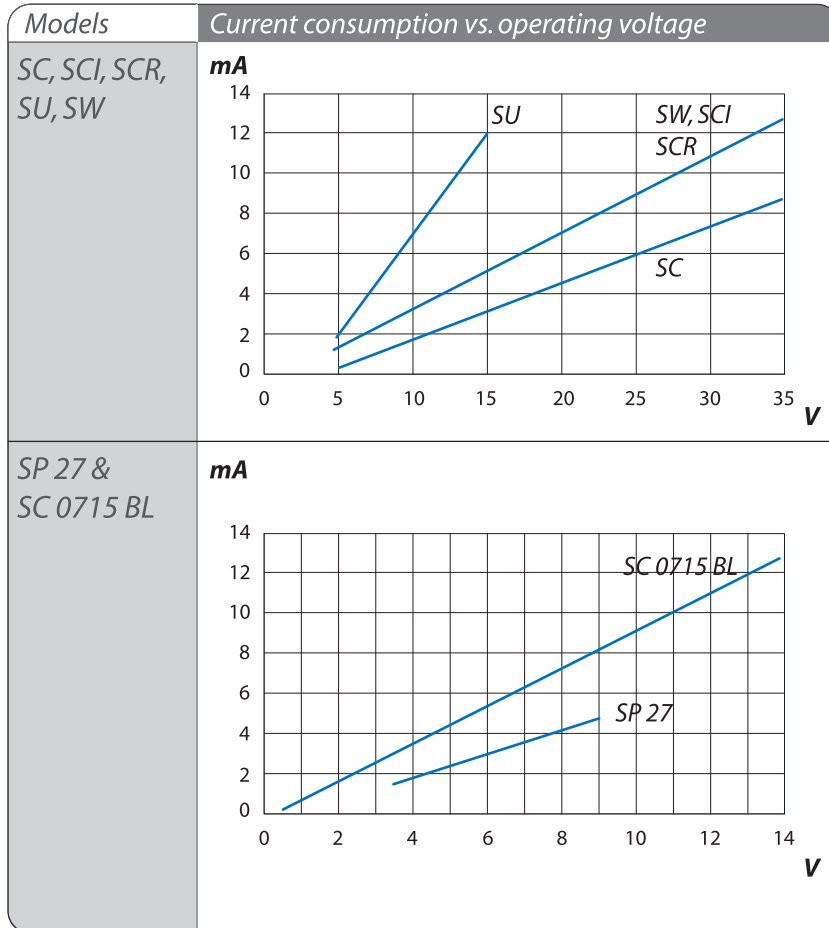

All measurements are made @ 12Vdc @ 1 meter in free air @ 21°C.

Sound pressure level vs. voltage

SC 235 A/B

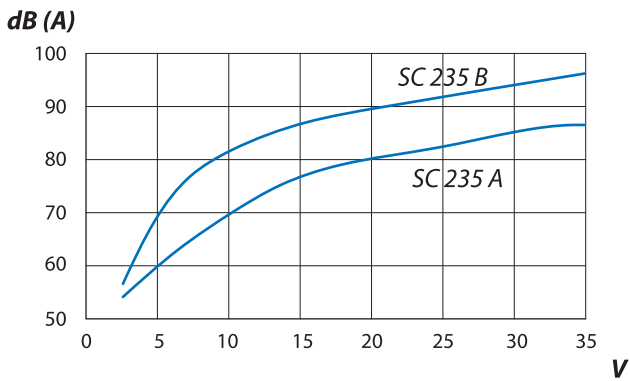

SCR 535 A/B

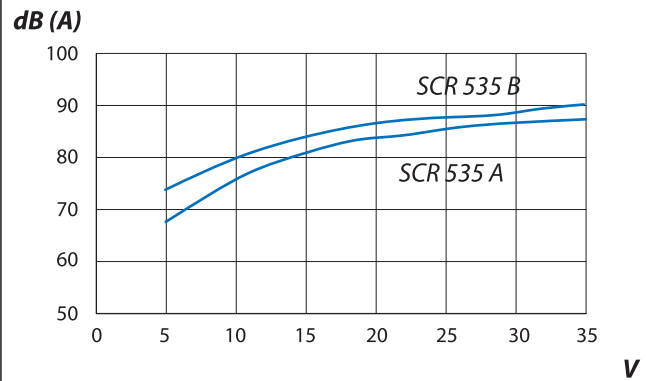

SCI 535 A/B

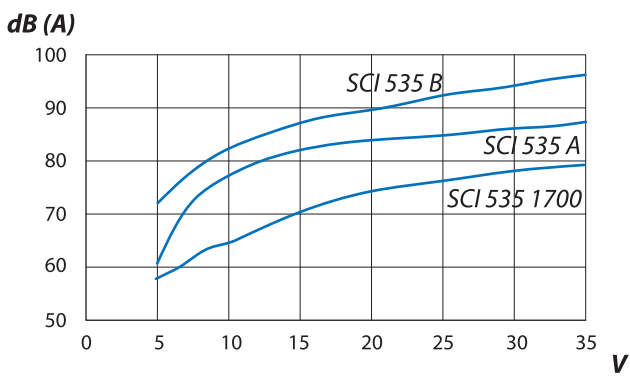

SW 535 B

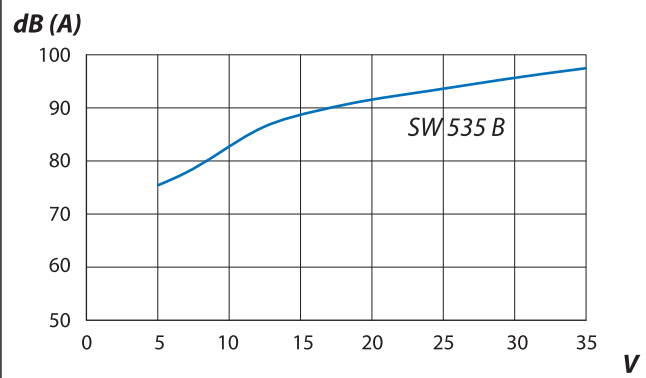

SUM 516 A1/A5, SULM 516 B1/B5, SULI 516 B1/B5

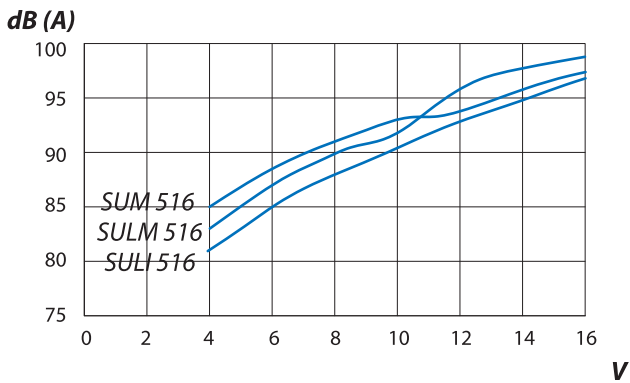

SULC 516 B, SUC 516 A/B

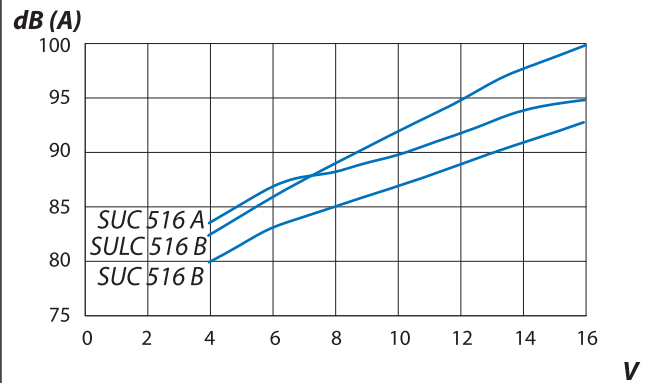

SP 27 & SC 0715 BL

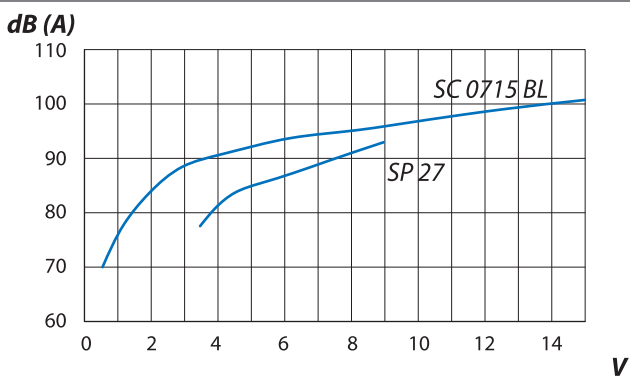

All measurements are made @ 12Vdc @ 1 meter in free air @ 21°C.



**DIMENSIONS** (All dimensions are in mm)

Round flange model	Square flange model	Mounting nut
<p>Note: all round and square flange models are available with all kinds of pin terminals.</p>		

**Models (2 pins) SC, SW (3 pins) SCR, SCI**

Pins	'fast-on' F	'fast-on' F2
<p>Note: control pin (CP) only with multifunction buzzers. <span style="float: right;">*0.8x2.3 Positioning lock</span></p>		

**Models (2 pins) SUC, SULC, SULI (3 pins) SUM, SULM**

**Pins**

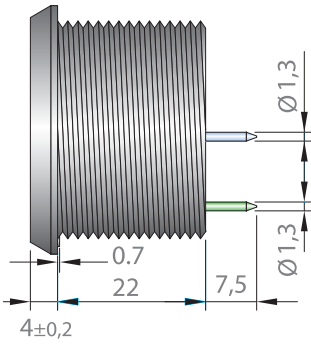

**'fast-on' F**

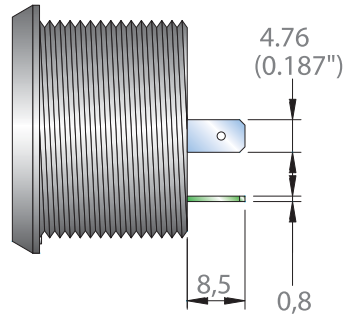

**'fast-on' F2**

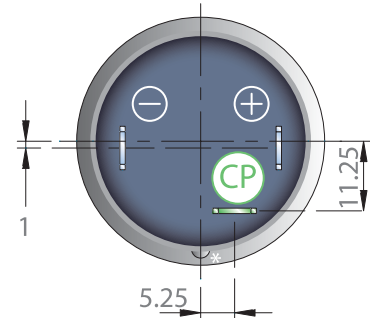
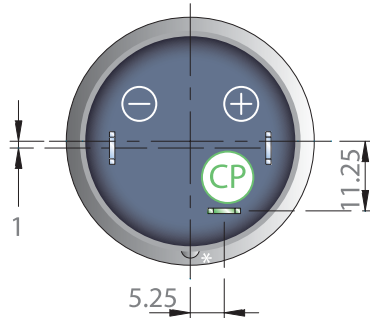
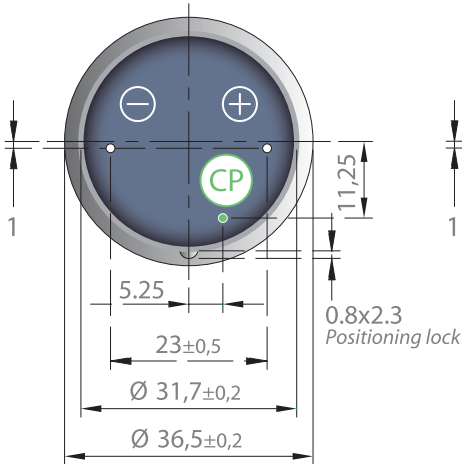
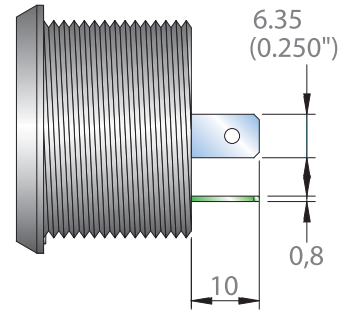

**Model SP27**

**Pins**

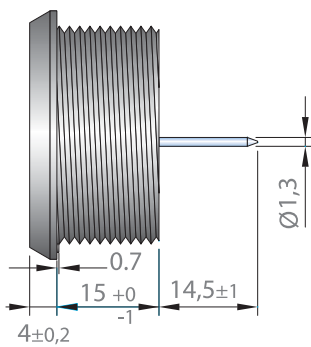

**'fast-on' F**

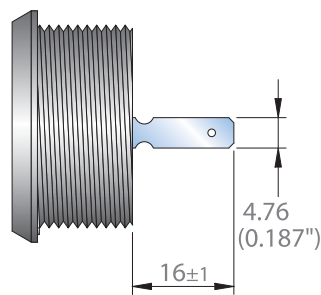

**'fast-on' F2**

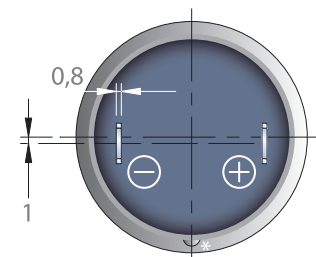
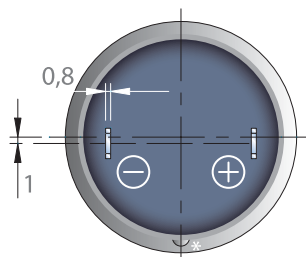
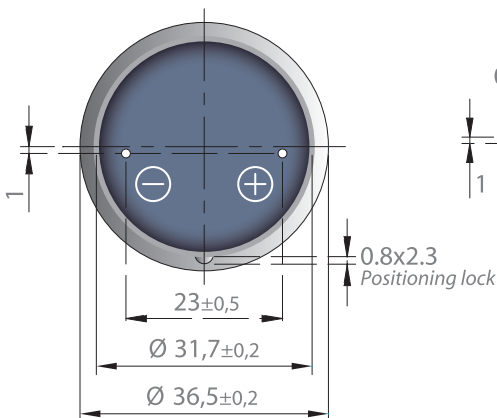
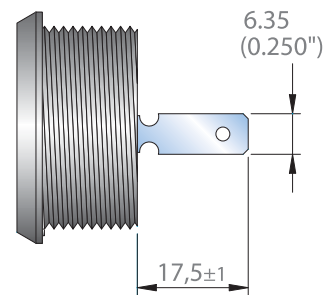

\*0.8x2.3  
Positioning lock

## ORDER OPTIONS STANDARD SERIES

CODE	Description
W100	With 2 wires: length 10cm (instead of pins).
W150	With 2 wires: length 15cm (instead of pins).
W300	With 2 wires: length 30cm (instead of pins).
ACR (acryl coating)	For applications under aggressive humid conditions, Sonitron also deliver a special model in which the piezo element is covered with a protective coating. Add ACR to the part number. The protective coating gives a complementary assurance against smog; all standard models are perfectly waterproof (IP67) without the mentioned coating.
Gasket (O-ring)	Rubber sealing ring for waterproof assembly. (standard delivered with SP7)

**To order an option add the suffix to the model number of the standard series.**

NUT All standard buzzers are delivered with a mounting nut.

## MOUNTING GUIDELINES

- Printed circuit-board:
  - by soldering the terminals.
- Front panel mounting:
  - Panel mounting with a plastic nut.  
the buzzers can be mounted in panels up to 14 mm thickness (SP27 max. 7 mm). They are locked with a locking pin (dimensions 0.8x2.3mm) and secured to the panel with a plastic nut. Foresee a hole of diameter 32 mm (1.14"). Maximum torque on plastic nut: 6 Nm (wrench size 38mm).  
The step of the thread is 1.5 mm (M32x1.5).

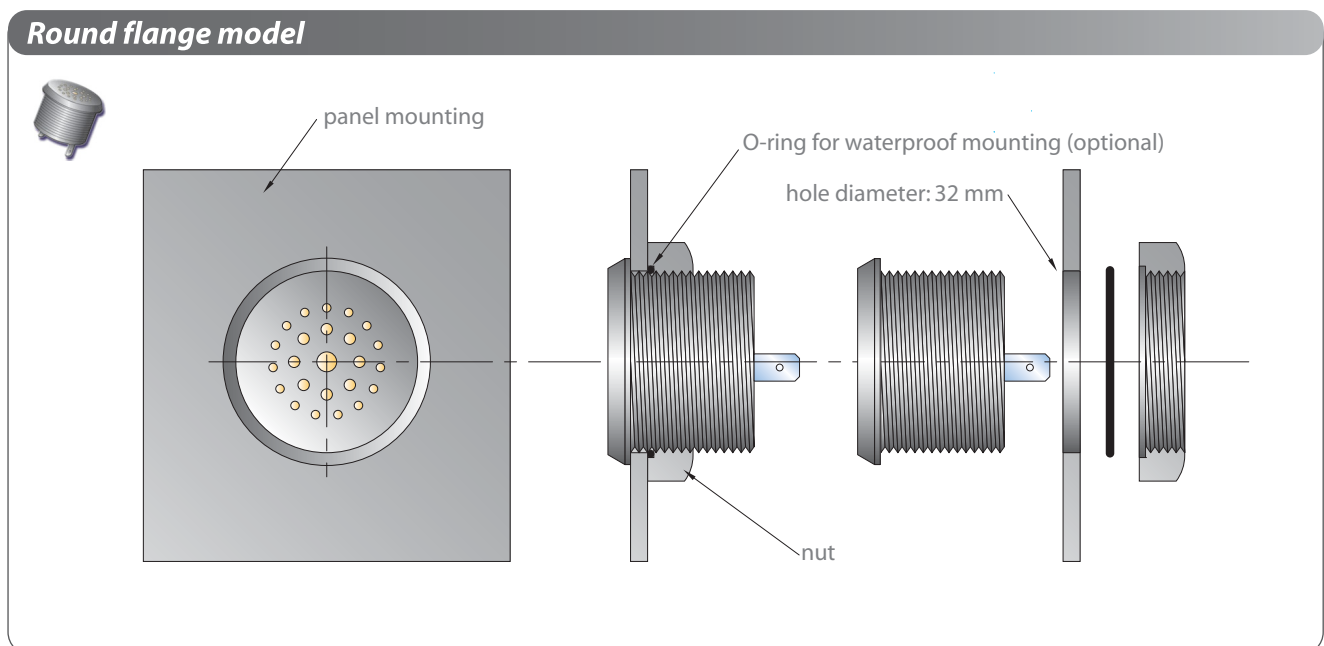

**Square flange model**



Panel mounting square flange model with screws (M4).  
 The square flange model can be mounted with 4x M4 screws instead of using the plastic nut. for waterproof mounting of the square flange model the nut must also be screwed on together with the optional O-ring.

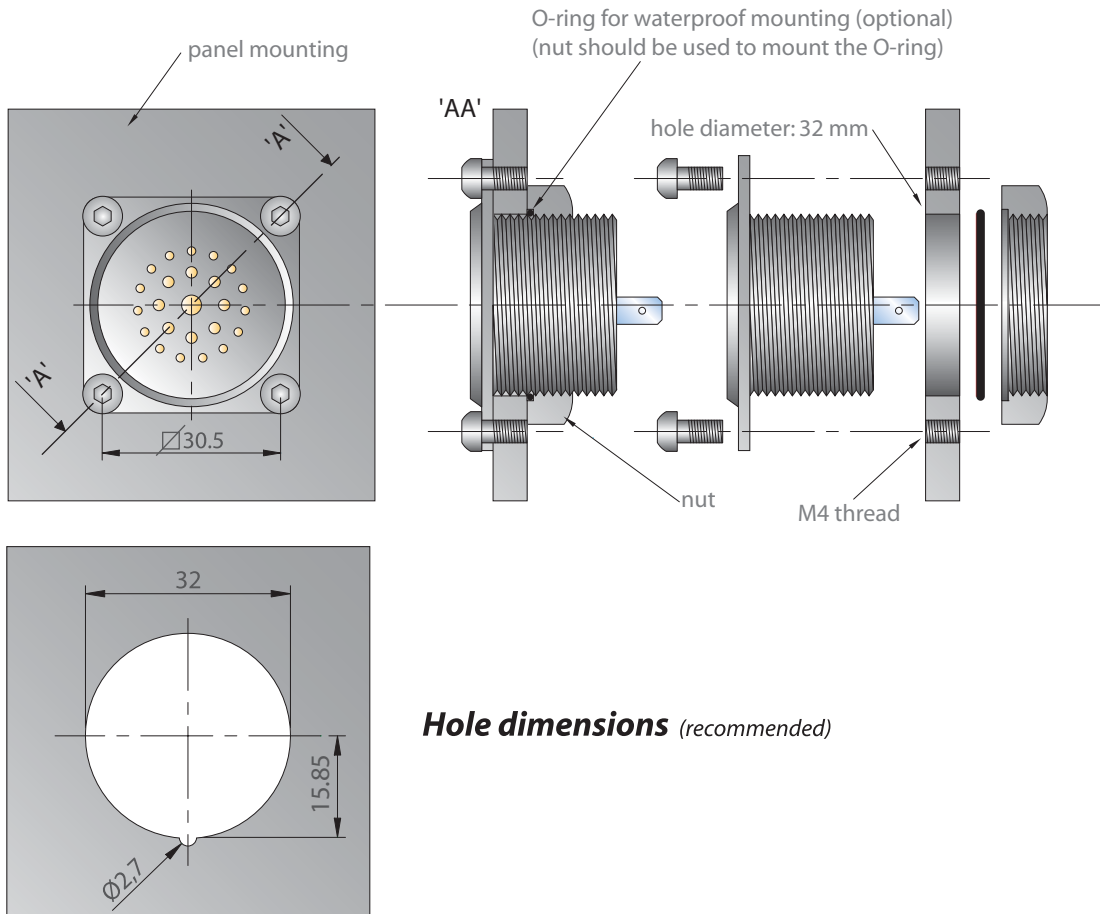

**Hole dimensions** (recommended)

**SPECIAL CERTIFICATES EEx 1**



**GAS-EXPLOSIVE CONFORMITY**

Our standard series construction structure has been tested by:

BERGBAU-VERSUCHSSTREKKE  
 Postfach 140120  
 4600 Dortmund 14  
 Date: 28.09.1987

The result was that we obtained the following certificate:

Intrinsically safe (EEx ia I) Ex IM 1 cert. ISSeP03ATEX099U

Hugo R. Michiels  
 President and CEO  
 SONITRON N.V.

## PRODUCT CODIFICATION

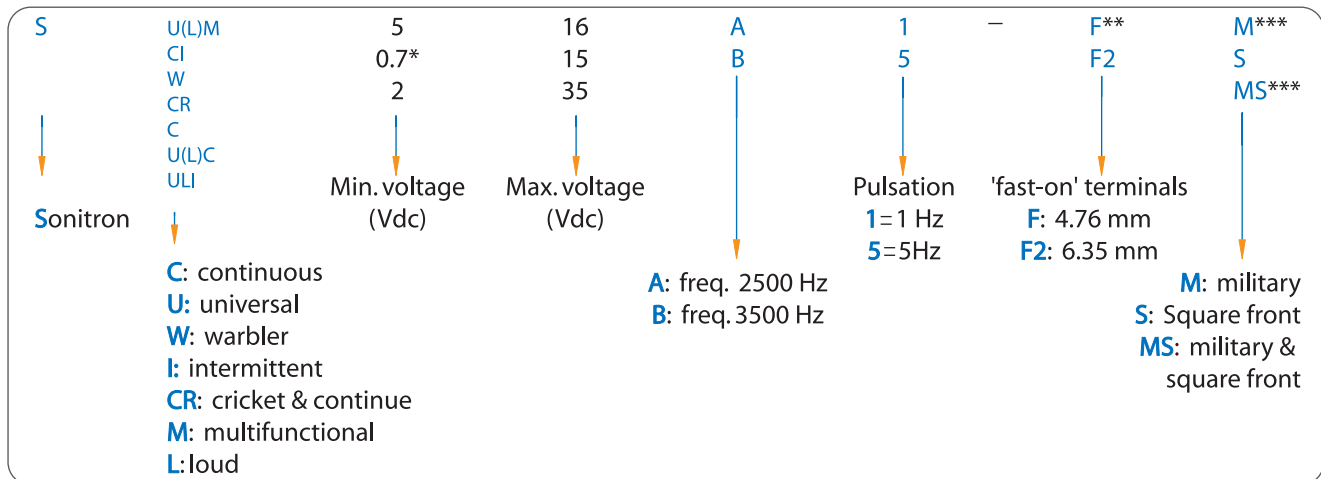

\*0.7: 0.7 Vdc minimum voltage of the SC 0715 BL

F\*\* If no terminal specification, the model is standard delivered with round pins, diameter 1.5 mm. Fast-on terminals are available in 2 dimensions: F= 4,76 mm (0,187 inch) or F2 = 6,35 mm (0,250 inch).

M\*\*\* Military norm MIL STD 202

## LIST OF AVAILABLE PRODUCT TYPES

SC 235 A SC 235 A F SC 235 A F2 SC 235 A F M SC 235 A F2 M SC 235 A S SC 235 A F S SC 235 A F2 S SC 235 A F MS SC 235 A F2 MS	SC 235 B SC 235 B F SC 235 B F2 SC 235 B F M SC 235 B F2 M SC 235 B S SC 235 B F S SC 235 B F2 S SC 235 B F MS SC 235 B F2 MS	SC 0715 BL SC 0715 BL F SC 0715 BL F2 SC 0715 BL F M SC 0715 BL F2 M SC 0715 BL S SC 0715 BL F S SC 0715 BL F2 S SC 0715 BL F MS SC 0715 BL F2 MS	SP27 SP27 F SP27 F2 SP27 F M SP27 F2 M SP27 S SP27 F S SP27 F2 S SP27 F MS SP27 F2 MS	SCI 535 A1 SCI 535 A1 F SCI 535 A1 F2 SCI 535 A1 F M SCI 535 A1 F2 M SCI 535 A1 S SCI 535 A1 F S SCI 535 A1 F2 S SCI 535 A1 F MS SCI 535 A1 F2 MS SCI 535 1700	SCI 535 A5 SCI 535 A5 F SCI 535 A5 F2 SCI 535 A5 F M SCI 535 A5 F2 M SCI 535 A5 S SCI 535 A5 F S SCI 535 A5 F2 S SCI 535 A5 F MS SCI 535 A5 F2 MS
SCI 535 B1 SCI 535 B1 F SCI 535 B1 F2 SCI 535 B1 F M SCI 535 B1 F2 M SCI 535 B1 S SCI 535 B1 F S SCI 535 B1 F2 S SCI 535 B1 F MS SCI 535 B1 F2 MS	SCI 535 B5 SCI 535 B5 F SCI 535 B5 F2 SCI 535 B5 F M SCI 535 B5 F2 M SCI 535 B5 S SCI 535 B5 F S SCI 535 B5 F2 S SCI 535 B5 F MS SCI 535 B5 F2 MS	SCR 535 A SCR 535 A F SCR 535 A F2 SCR 535 A F M SCR 535 A F2 M SCR 535 B S SCR 535 A F S SCR 535 A F2 S SCR 535 A F MS SCR 535 A F2 MS	SCR 535 B SCR 535 B F SCR 535 B F2 SCR 535 B F M SCR 535 B F2 M SCR 535 B S SCR 535 B F S SCR 535 B F2 S SCR 535 B F MS SCR 535 B F2 MS	SUC 516 A SUC 516 A F SUC 516 A F2 SUC 516 A F M SUC 516 A F2 M SUC 516 A S SUC 516 A F S SUC 516 A F2 S SUC 516 A F MS SUC 516 A F2 MS	SUC 516 B SUC 516 B F SUC 516 B F2 SUC 516 B F M SUC 516 B F2 M SUC 516 B S SUC 516 B F S SUC 516 B F2 S SUC 516 B F MS SUC 516 B F2 MS
SULC 516 B SULC 516 B F SULC 516 B F2 SULC 516 B F M SULC 516 B F2 M SULC 516 B S SULC 516 B F S SULC 516 B F2 S SULC 516 B F MS SULC 516 B F2 MS	SUM 516 A1 SUM 516 A1 F SUM 516 A1 F2 SUM 516 A1 F M SUM 516 A1 F2 M SUM 516 A1 S SUM 516 A1 F S SUM 516 A1 F2 S SUM 516 A1 F MS SUM 516 A1 F2 MS	SUM 516 A5 SUM 516 A5 F SUM 516 A5 F2 SUM 516 A5 F M SUM 516 A5 F2 M SUM 516 A5 S SUM 516 A5 F S SUM 516 A5 F2 S SUM 516 A5 F MS SUM 516 A5 F2 MS	SULI 516 B1 SULI 516 B1 F SULI 516 B1 F2 SULI 516 B1 F M SULI 516 B1 F2 M SULI 516 B1 S SULI 516 B1 F S SULI 516 B1 F2 S SULI 516 B1 F MS SULI 516 B1 F2 MS	SULI 516 B5 SULI 516 B5 F SULI 516 B5 F2 SULI 516 B5 F M SULI 516 B5 F2 M SULI 516 B5 S SULI 516 B5 F S SULI 516 B5 F2 S SULI 516 B5 F MS SULI 516 B5 F2 MS	SULM 516 B1 SULM 516 B1 F SULM 516 B1 F2 SULM 516 B1 F M SULM 516 B1 F2 M SULM 516 B1 S SULM 516 B1 F S SULM 516 B1 F2 S SULM 516 B1 F MS SULM 516 B1 F2 MS
SULM 516 B5 SULM 516 B5 F SULM 516 B5 F2 SULM 516 B5 F M SULM 516 B5 F2 M SULM 516 B5 S SULM 516 B5 F S SULM 516 B5 F2 S SULM 516 B5 F MS SULM 516 B5 F2 MS	SW 535 B SW 535 B F SW 535 B F2 SW 535 B F M SW 535 B F2 M SW 535 B S SW 535 B F S SW 535 B F2 S SW 535 B F MS SW 535 B F2 MS	SP 7 SP 7 F SP 7 F2 SP 7 M SP 7 M SP 7 S SP 7 F S SP 7 F2 S SP 7 F MS SP 7 F2 MS			

## MILITARY MODELS



Our patented bended edge membranes permit us to realize military applications. We deliver since more than 30 years piezo acoustic components on military specifications.

Our products are used in portable radio's, de-icing detection, airplane cockpit alarms...

We are since more than 20 years Navo approved for several models.

We warned in time at critical moments...

### Military test conditions MIL STD202

The military models guarantee a quality superior to the classic models. On top of the standard specifications, the military models are tested as follows:

Test	Method MIL STD202	Test conditions
Thermal Shock	107	A
Humidity	103	B
Salt Spray	101	A
Shock	213 B	H
Vibration	201 A	none
Terminal strength	211	A (10 Lbs, 2 cycles)

The different tests are summarised below. The detailed procedures are available upon special request.

**Thermal shock test 107 method A:** The thermal shock test is performed to determine the resistance of a part to exposures at extremes of high and low temperatures, and to the shocks of alternate exposures to these extremes, such as would be experienced when equipment or parts are transferred to and from heated shelters in arctic areas. The products are exposed to a flow of air at different temperatures for at least 5 cycles.

**Humidity test 103 method B:** This test is performed to evaluate the properties of materials used in components as they are influenced by the absorption and diffusion of moisture and moisture vapour.

This accelerated environmental test is accomplished by the continuous exposure of the specimen to high relative humidity at an elevated temperature during 96 hours.

**Salt spray test 101 method A:** The purpose of this test is to define if the product is resistant to salt spray. This accelerated laboratory corrosion test simulates the effects of seacoast atmospheres on metals. The coating of the product is subjected to a fine mist of salt solution during 96 hours.

**Shock test 213B method H:** The shock test (Sawtooth pulse during 6Ms) is conducted for the purpose of determining the suitability of component parts and subassemblies of electrical and electronic components when subjected to shocks such as those which may be expected as a result of rough handling, transportation and military operations. The design of the shock machine is not specified, but shock pulse waveforms are specified with tolerances.

**Vibration test 201 A:** The vibration test is used to determine the effects on component parts of vibration within the predominant frequency ranges and magnitudes that may be encountered during the field service. The specimen is mounted on a special apparatus and subjected to a simple harmonic motion.

**Thermal strength test 211 method A:** This test is performed to determine if the design of the product and its method of attachment can withstand one or more of the applicable mechanical stresses to which they will be subjected during installation or disassembly in equipment. This pull of tension test is gradually applied and then maintained for a period of 5 to 10 seconds.

## NATO approved models

All standard models can be delivered in a military version. All military models have flame retardant ABS housings in olive green, fast-on terminals and the membrane is foreseen with a special protective coating.

Ref. Nr.:	NSN (NATO stock number)	Type
SC 235 A	6350-13-113-8057	4
SC 235 B	6350-13-112-5782	
SC 235 AF2 BLACK	6350-13-116-5836	1
SC 235 AF2	6350-13-120-1787	4
SC 235 BF2	6350-13-120-1788	
SC 235 AFM	6350-13-116-8221	4
SC 235 A-M	6350-13-118-3500	1
SC 235 BF	6350-13-113-4698	4
SC 235 B FM	6350-13-113-4504	
SUM 516 A	6350-13-113-6319	4
SULM 516 B1 FM	6350-13-113-6108	4
SULM 516 B5	6350-13-120-6689	1
SULM 516 B5-F	6350-13-118-9573	
SCI 535 A1-F2	6350-13-119-8080	4
SCI 535A1-M Green	6350-13-118-1179	4
SCI 535 A1 FM	6350-13-114-1876	4
SCI 535 B1 FM	6350-13-113-6092	4
SCI 535 B1	6350-13-114-8156	1
SCI535 B1-Black	6350-13-1205625	1
SCI 535 B1-F2	6350-13-116-9171	1
SCI 535 B5	6350-13-113-1553	
SCI 535 B5-F-48X05N	6350-13-118-3502	4
SCI 535 B5-F	6350-13-1206614	1
SCI 535 B5-FM	6350-13-113-1553	4
SCR 535 A	6350-13-113-2787	4
SCI 535 A1-F2	6350-13-119-8080	
SCR 535 B	6350-13-115-0297	4
SCR 535 B FM	6350-13-114-1875	1
SC 0715 BLF	6350-13-115-6688	1
SC 0715 BL-F2-M	6350-13-116-8321	4
SC 0715 BL	6350-13-118-6691	4
SMA-21B-P17,5	6350-13-114-5188	4
SMA-21B-P10	6350-13-115-6615	1
SMAT-21	5965-13-117-8832	4
SMA-21-P17.5	6350-13-1207739	1
SMA-21L-P17.5	6350-13-118-8899	4
SMA-24A-P10	6350-14-501-0602	
SMA-30-P20.32	6350-13-119-4461	4
SW 535 B	6350-13-119-7615	1
SW 535B-M	6350-13-118-2999	4
SP27-F-M	6350-13-118-4720	2

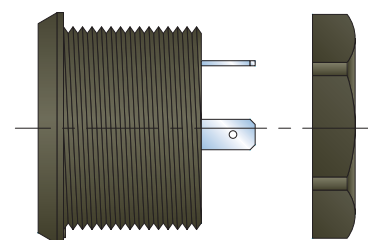
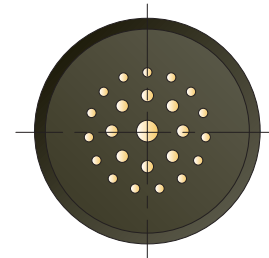

## MODELS ON REQUEST

The standard buzzers can be modified upon request in order to deliver a product meeting the requirements of the customer's application.

- Upon special request all standard models are also available in GREY, BLACK or GREEN (khaki). Please add GREY, BLACK or GREEN to the part number if the required colour is different from the one specified as standard.
- For applications under aggressive humid conditions, Sonitron also deliver a special model in which the piezo element is covered with a protective coating. Add ACR to the part number. The protective coating gives a complementary assurance against smog; all standard models are perfectly waterproof (IP67) without the mentioned coating.
- Different pin terminal lengths, straight or bent, can be custom made.
- The frequency, indicated in the present catalogue, has an accuracy of  $\pm 15\%$ . Standard buzzers with an improved frequency accuracy (up to  $\pm 2\%$ ) are available upon special customer request.

For more information mail to: [support@sonitron.be](mailto:support@sonitron.be)

## PACKAGING

All standard buzzers are packed in polystyrene boxes of 26.5 x 26.5 cm ; 25 pieces per box.

