



# STPR1620CG/CT/CR

## ULTRA-FAST RECOVERY RECTIFIER DIODES

### MAIN PRODUCTS CHARACTERISTICS

$I_{F(AV)}$	2 x 8 A
$V_{RRM}$	200 V
$T_j(max)$	150°C
$V_F(max)$	0.99 V
$trr(max)$	30 ns

### FEATURES

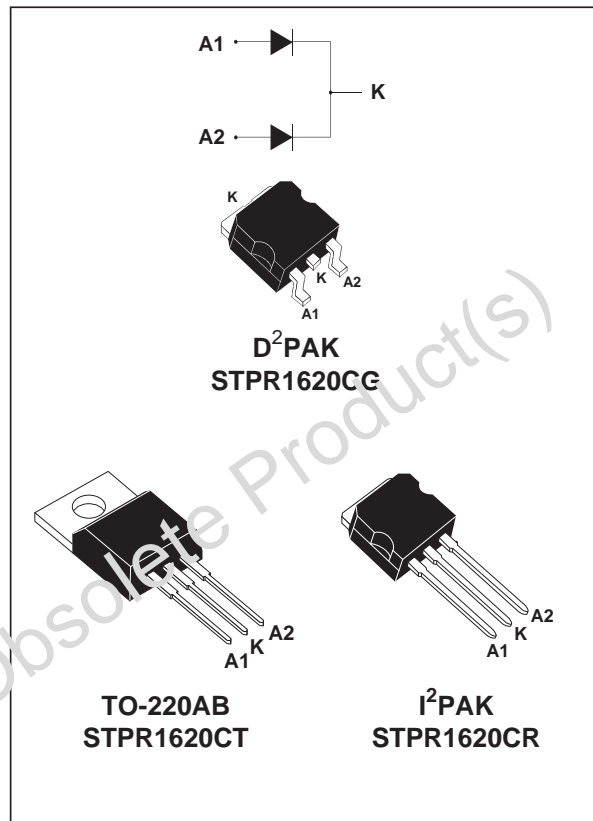
- SUITED FOR SMPS
- LOW LOSSES
- LOW FORWARD AND REVERSE RECOVERY TIME
- HIGH SURGE CURRENT CAPABILITY

### DESCRIPTION

Low cost dual center tap rectifier suited for Switched Mode Power Supplies and high frequency DC to DC converters. Packaged in D<sup>2</sup>PAK, I<sup>2</sup>PAK or TO-220AB, this device is intended for use in low voltage, high frequency inverters, free wheeling and polarity protection applications.

### ABSOLUTE RATINGS (limiting values, per diode)

Symbol	Parameter		Value	Unit
$V_{RRM}$	Repetitive peak reverse voltage		200	V
$I_{F(RMS)}$	RMS forward current		20	A
$I_{F(AV)}$	Average forward current $\delta = 0.5$	$T_c=120^\circ\text{C}$ Per diode Per device	8 16	A
$I_{FSM}$	Surge non repetitive forward current	$t_p=10\text{ms}$ sinusoidal	80	A
$T_{stg}$	Storage temperature range		- 65 to + 150	°C
$T_j$	Maximum operating junction temperature		150	°C



## STPR1620CG / STPR1620CT / STPR1620CR

### THERMAL RESISTANCES

Symbol	Parameter		Value	Unit
R <sub>th(j-c)</sub>	Junction to case	Per diode	3.0	°C/W
		Total	1.8	°C/W
R <sub>th(c)</sub>		Coupling	0.6	°C/W

When the diodes 1 and 2 are used simultaneously :

$$\Delta T_{j(\text{diode } 1)} = P(\text{diode } 1) \times R_{th(j-c)} (\text{Per diode}) + P(\text{diode } 2) \times R_{th(c)}$$

### STATIC ELECTRICAL CHARACTERISTICS

Symbol	Test conditions		Min.	Typ.	Max.	Unit
I <sub>R</sub> *	T <sub>j</sub> = 25°C	V <sub>R</sub> = V <sub>RRM</sub>			50	μA
	T <sub>j</sub> = 100°C			0.2	0.6	mA
V <sub>F</sub> **	T <sub>j</sub> = 125°C	I <sub>F</sub> = 8 A		0.8	0.99	V
	T <sub>j</sub> = 125°C	I <sub>F</sub> = 16 A		0.95	1.20	
	T <sub>j</sub> = 25°C	I <sub>F</sub> = 16 A			1.25	

Pulse test : \* tp = 5 ms, δ < 2 %

\*\* tp = 380 μs, δ < 2 %

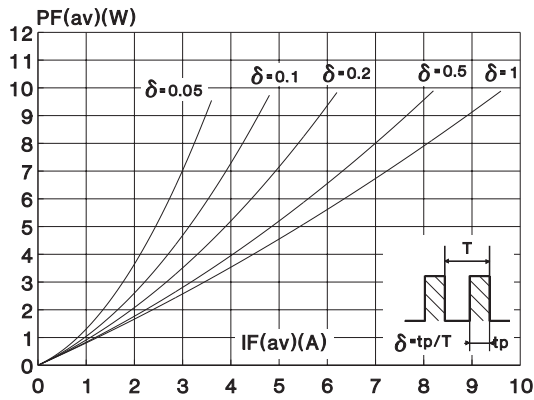
To evaluate the conduction losses use the following equation :

$$P = 0.78 \times I_{F(AV)} + 0.026 \times I_{F(RMS)}^2$$

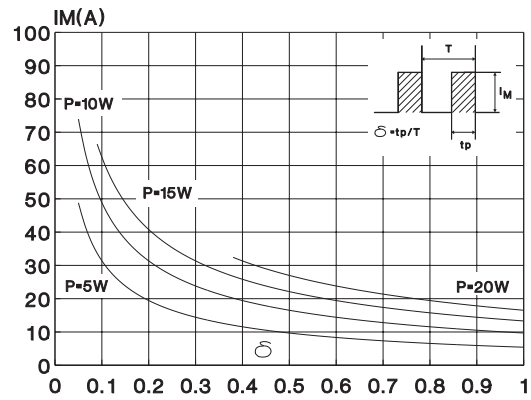
### RECOVERY CHARACTERISTICS

Symbol	Test conditions		Min.	Typ.	Max.	Unit
trr	T <sub>j</sub> = 25°C	I <sub>F</sub> = 0.5A I <sub>R</sub> = 1A			30	ns
tfr	T <sub>j</sub> = 25°C	I <sub>F</sub> = 3A V <sub>FR</sub> = 1.1 x V <sub>F</sub> max		20		ns
V <sub>FP</sub>	T <sub>j</sub> = 25°C	I <sub>F</sub> = 3A		3		V

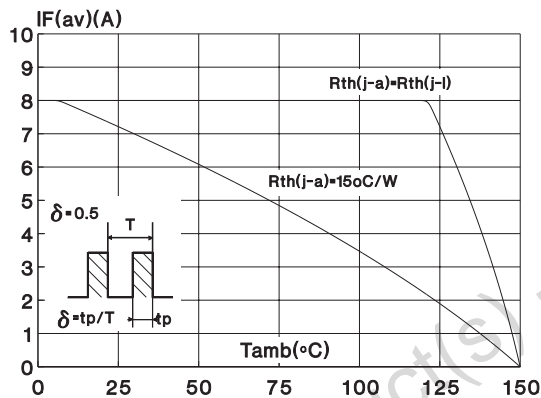
**Fig. 1:** Average forward power dissipation versus average forward current (per diode).



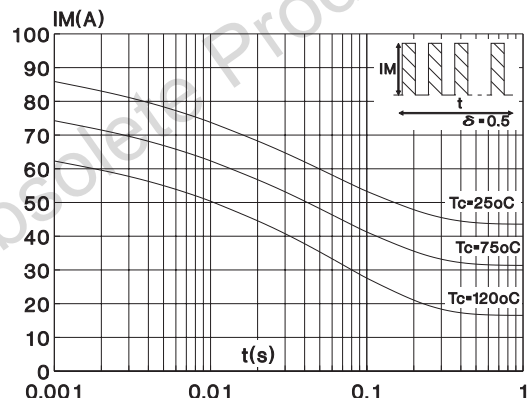
**Fig. 2:** Peak current versus form factor (per diode).



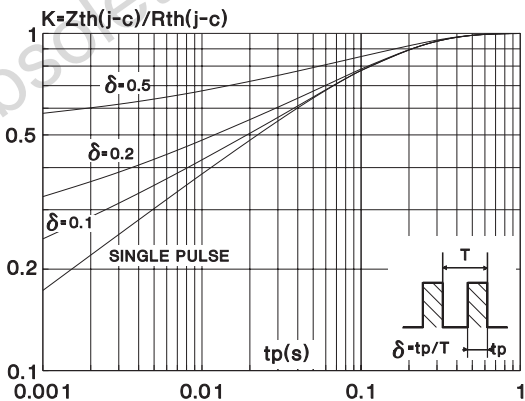
**Fig. 3:** Average current versus ambient temperature ( $\delta : 0.5$ , per diode).



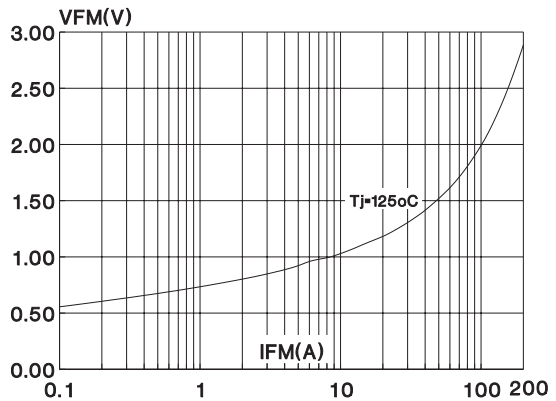
**Fig. 4:** Non repetitive surge peak forward current versus overload duration (maximum values, per diode).



**Fig. 5:** Relative variation of thermal transient impedance junction to case versus pulse duration (per diode).

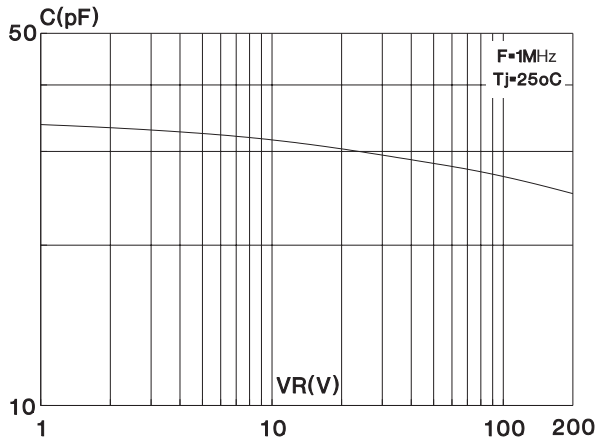


**Fig. 6:** Forward voltage drop versus forward current (maximum values, per diode).

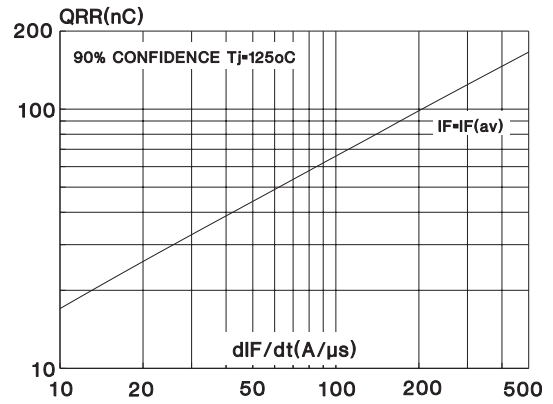


**STPR1620CG / STPR1620CT / STPR1620CR**

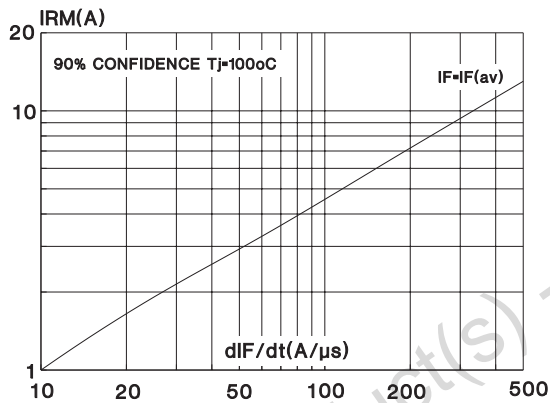
**Fig. 7:** Junction capacitance versus reverse voltage applied (typical values, per diode).



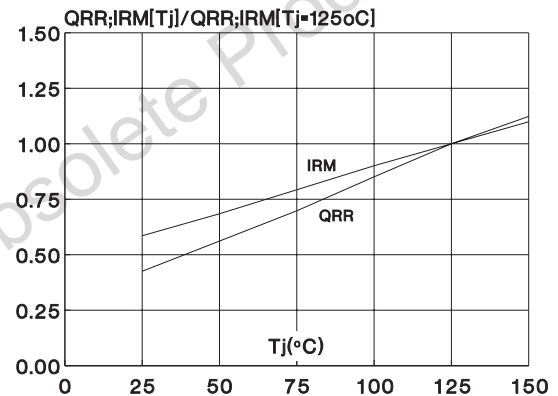
**Fig. 8:** Recovery charges versus  $di/dt$  (per diode).



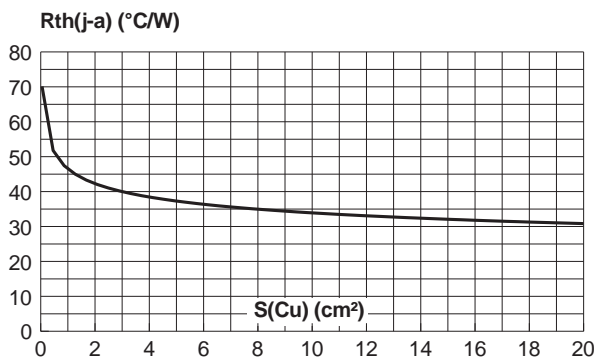
**Fig. 9:** Peak reverse current versus  $di/dt$  (per diode).



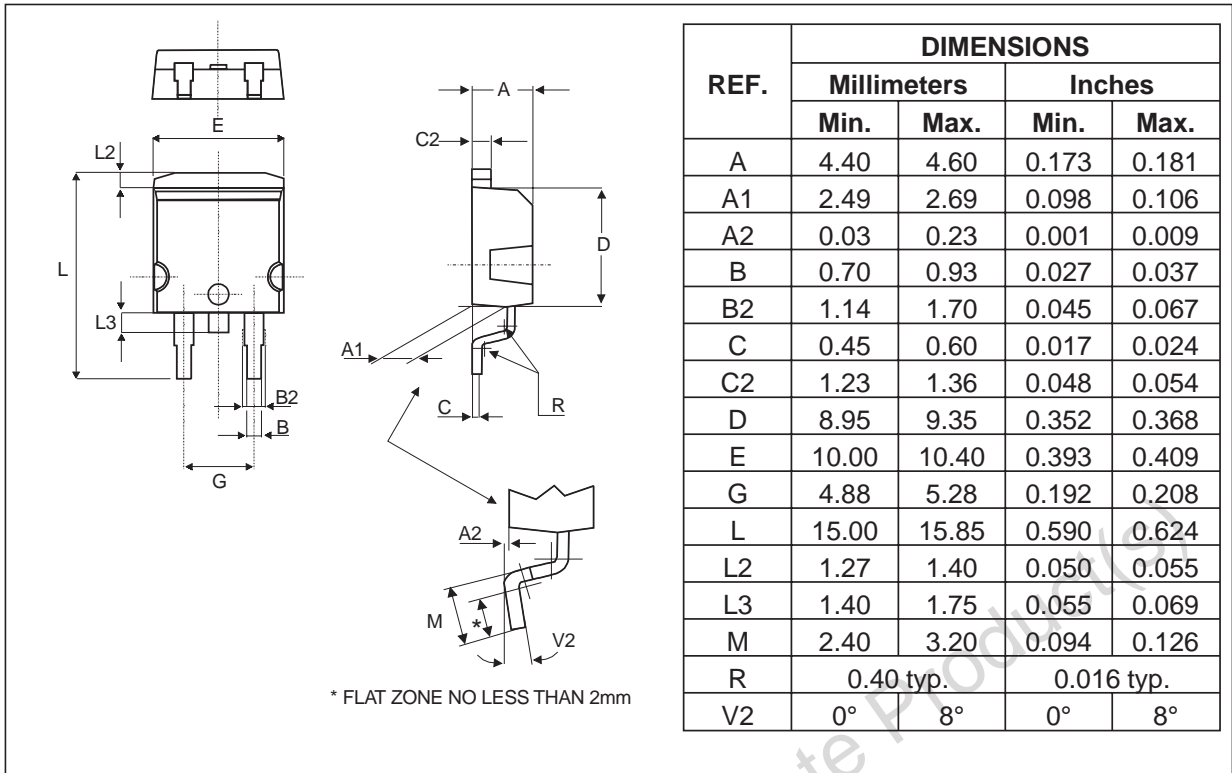
**Fig. 10:** Dynamic parameters versus junction temperature (per diode).



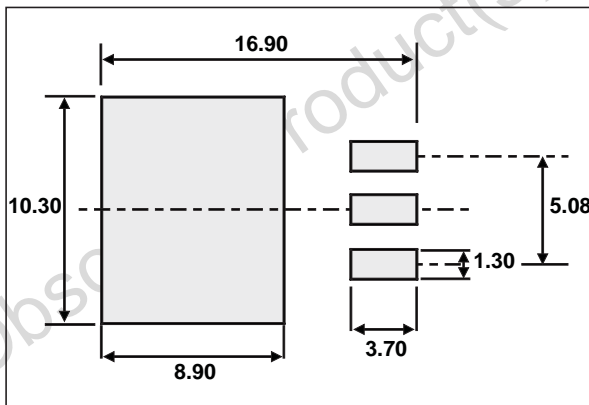
**Fig. 11:** Thermal resistance junction to ambient versus copper surface under tab (epoxy printed circuit board,  $CU = 35\mu s$ ) (STPR1620CG only).



**PACKAGE MECHANICAL DATA**  
D<sup>2</sup>PAK (Plastic)

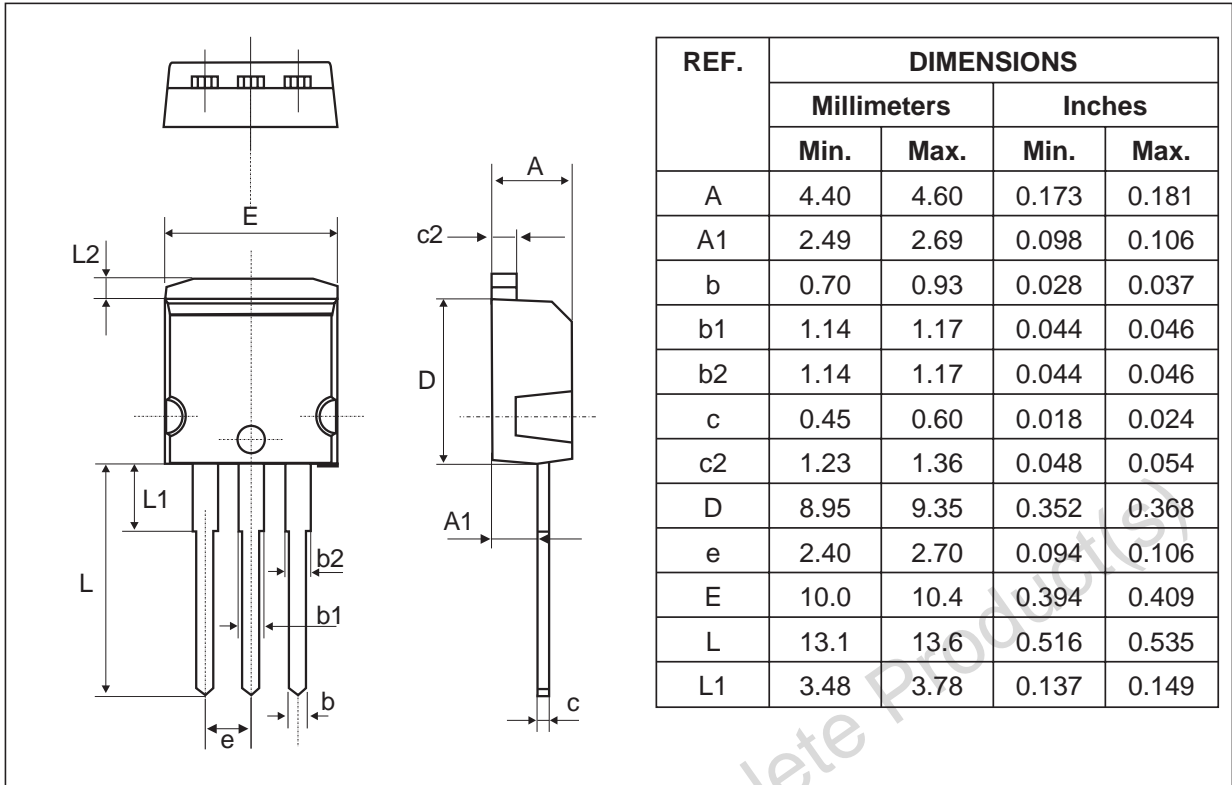


**FOOT PRINT (in millimeters)**



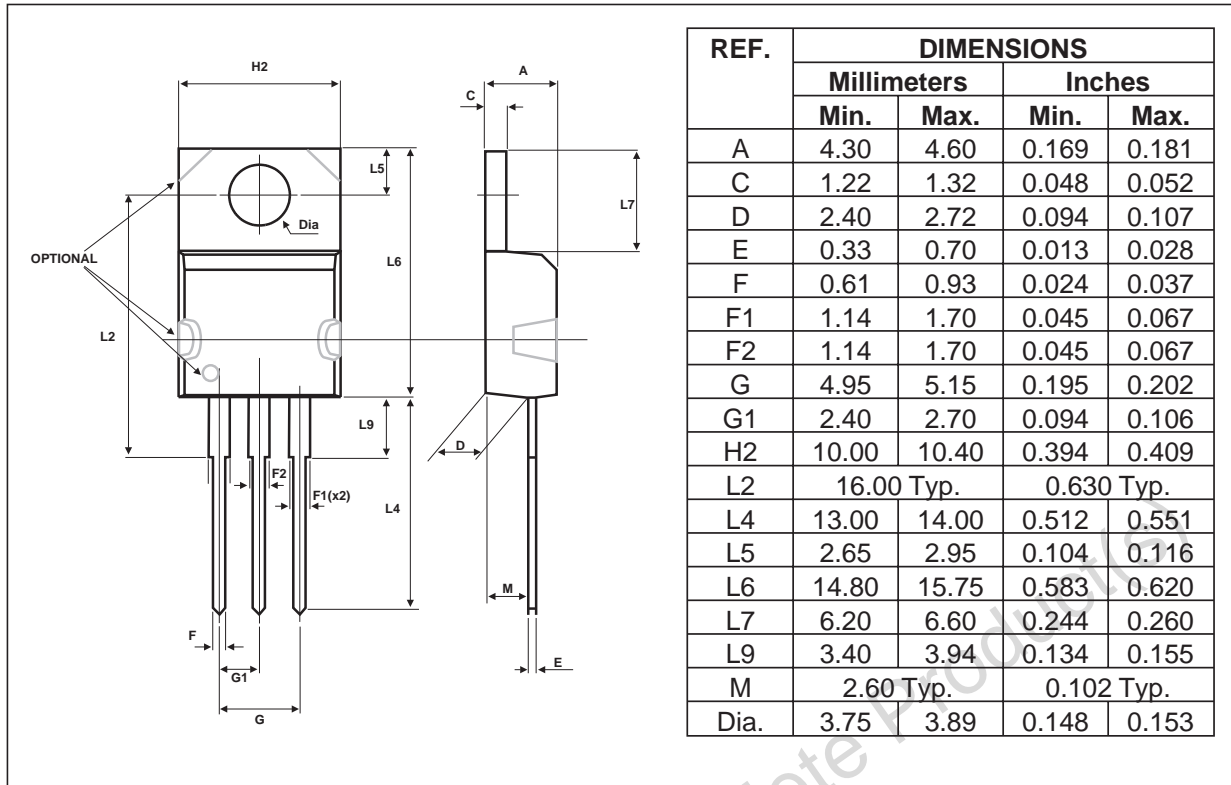
**STPR1620CG / STPR1620CT / STPR1620CR**

**PACKAGE MECHANICAL DATA**  
**i<sup>2</sup>PAK**



Obsolete Product(s) - Obsolete Product(s)

**PACKAGE MECHANICAL DATA**  
TO-220AB (JEDEC outline)



Ordering type	Marking	Package	Weight	Base qty	Delivery mode
STPR1620CT	STPR1620CT	TO-220AB	2.23 g	50	Tube
STPR1620CG	STPR1620CG	D <sup>2</sup> PAK	1.48 g	50	Tube
STPR1620CG-TR	STPR1620CG	D <sup>2</sup> PAK	1.48 g	1000	Tape & reel
STPR1620CR	STPR1620	I <sup>2</sup> PAK	1.49 g	50	Tube

- Cooling method : by conduction (C)
- Recommended torque value : 0.55N.m.
- Maximum torque value : 0.7N.m.
- Epoxy meets UL94,V0

Information furnished is believed to be accurate and reliable. However, STMicroelectronics assumes no responsibility for the consequences of use of such information nor for any infringement of patents or other rights of third parties which may result from its use. No license is granted by implication or otherwise under any patent or patent rights of STMicroelectronics. Specifications mentioned in this publication are subject to change without notice. This publication supersedes and replaces all information previously supplied. STMicroelectronics products are not authorized for use as critical components in life support devices or systems without express written approval of STMicroelectronics.

The ST logo is a registered trademark of STMicroelectronics  
 © 2002 STMicroelectronics - Printed in Italy - All rights reserved.  
 STMicroelectronics GROUP OF COMPANIES  
 Australia - Brazil - Canada - China - Finland - France - Germany  
 Hong Kong - India - Israel - Italy - Japan - Malaysia - Malta - Morocco - Singapore  
 Spain - Sweden - Switzerland - United Kingdom - United States.

<http://www.st.com>

