

***THIS DOCUMENT IS FOR MAINTENANCE
PURPOSES ONLY AND IS NOT
RECOMMENDED FOR NEW DESIGNS***

SL560

300MHz LOW NOISE AMPLIFIER

This monolithic circuit contains three very high performance transistors and associated biasing components in an eight-lead TO-5 package forming a 300MHz low noise amplifier. The configuration employed permits maximum flexibility with minimum use of external components. The SL560C is a general purpose low noise, high frequency gain block.

The device is also available as the SL560AC which has guaranteed operation over the fully Military Temperatures Range and is screened to MIL-STD-883 Class B. Data is available separately.

FEATURES

- Gain up to 40dB
- Noise Figures less than 2dB (Rs 200 ohm)
- Bandwidth 300MHz
- Supply Voltage 2-15V (Depending on Configuration)
- Low Power Consumption

APPLICATIONS

- Radar IF Preamplifiers
- Infra-Red Systems Head Amplifiers
- Amplifiers in Noise Measurement Systems
- Low Power Wideband Amplifiers
- Instrumentation Preamplifiers
- 50 ohm Line Drivers
- Wideband Power Amplifiers
- Wideband Dynamic Range IF Amplifiers
- Aerial Preamplifiers

ABSOLUTE MAXIMUM RATINGS

Supply voltage	+15V
Storage temperature	
SL560C DP	-55°C to +150°C
SL560C CM	-65°C to +150°C
Junction temperature	
SL560C DP	+150°C
SL560C CM	+175°C
Operating temperature range	
SL560C DP	-30°C to +85°C
SL560C CM	-55°C to +125°C
Thermal resistance	
Chip-to-ambient	
SL560C CM	225°C/W
SL560C DP	111°C/W
Chip-to-case	
SL560C CM	65°C/W
SL560C DP	71°C/W

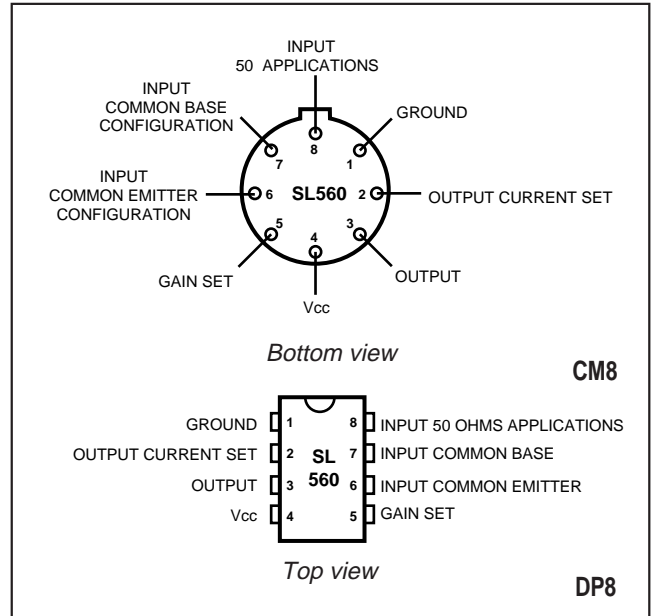

Fig.1 Pin connections

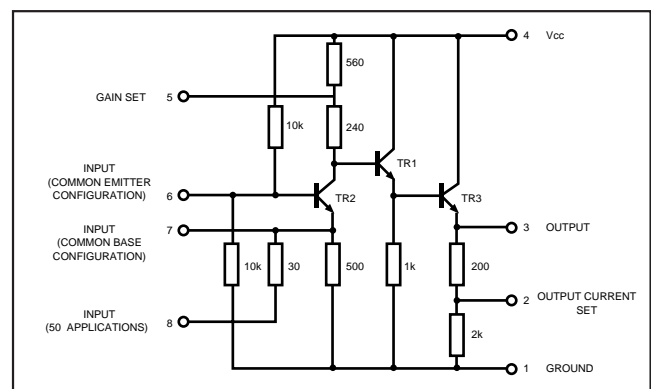

Fig.2 SL560C circuit diagram

ORDERING INFORMATION

SL560 C CM
SL560 C DP
5962-90520 (SMD)

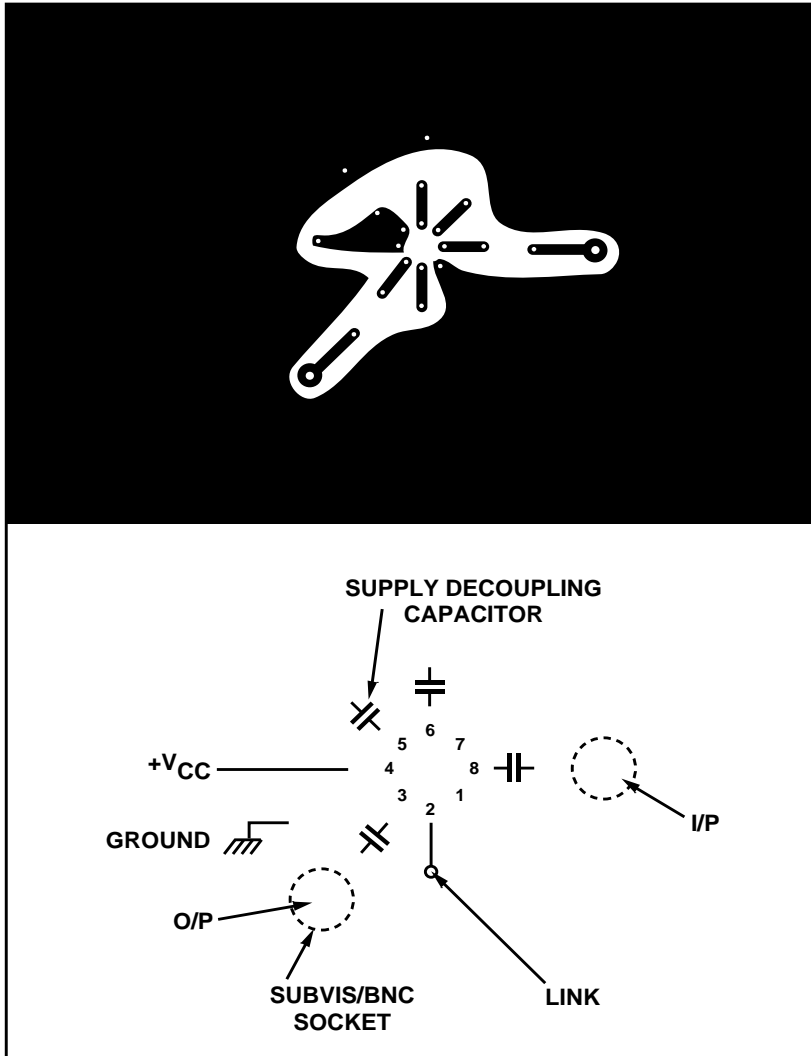

Fig.3 PC layout for 50Ω line driver (see Fig.6)

ELECTRICAL CHARACTERISTICS

These characteristics are guaranteed over the following conditions (unless otherwise stated)

Frequency = 30MHz; $V_{CC}=6V$; $R_S = R_L = 50\Omega$; $T_{AMB}=22^\circ C \pm 2^\circ C$; Test Circuit: Fig.6

Characteristic	Min.	Typ.	Max.	Units	Conditions
Small signal voltage gain	11	14	17	dB	10MHz - 220MHz $V_{CC}6V$ $V_{CC} = 9V$ $R_S = 200\Omega$ $R_S = 50\Omega$
Gain flatness		± 1.5		dB	
Upper cut-off frequency		250		MHz	
Output swing	+5	+7		dBm	
		+11		dBm	
Noise figure (common emitter)		1.8		dB	
Supply current		3.5	30	mA	

CIRCUIT DESCRIPTION

Three high performance transistors of identical geometry are employed. Advanced design and processing techniques enable these devices to combine a low base resistance ($R_{bb'}$) of 17Ω (for low noise operation) with a small physical size - giving a transition frequency, f_T , in excess of 1GHz.

The input transistor (TR1) is normally operating in common base, giving a well defined low input impedance. The full voltage gain is produced by this transistor and the output voltage produced at its collector buffered by the two emitter followers (TR2 and TR3). To obtain maximum bandwidth the capacitance at the collector of TR1 must be minimised. Hence, to avoid bonding pad and can capacitances, this point is not brought out of the package. The collector load resistance of TR1 is split, the tapping being accessible via pin 5. If required, an external roll-off capacitor can be fixed to this point.

The large number of circuit nodes accessible from the outside of the packages affords great flexibility, enabling the operating current and circuit configuration to be optimised for any application. In particular, the input transistor (TR1) can be operated in common emitter mode by decoupling pin 7 and using 6 as the input. In this configuration, a 2dB noise figure ($R_S = 200\Omega$) can be achieved. This configuration can give a gain of 35dB with a bandwidth of 300MHz (see figs. 10 and 11).

Because the transistors used in the SL560C exhibit a high value of f_T , care must be taken to avoid high frequency instability. Capacitors of small physical size should be used, the leads of which must be short as possible to avoid oscillation brought about by stray inductance. The use of a ground plane is recommended.

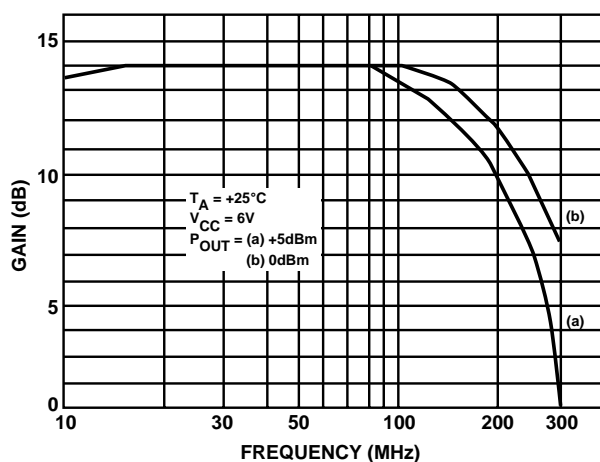

Fig.4 Frequency response, small signal gain is of a typical device

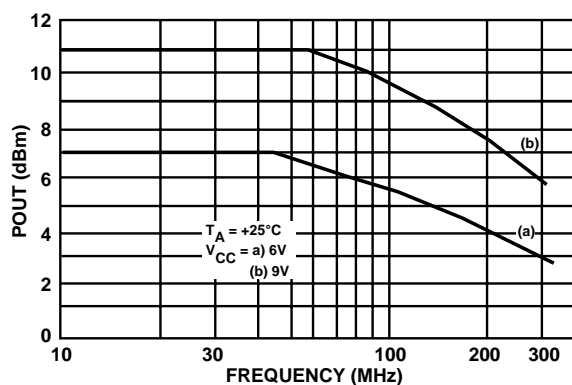

Fig.5. Frequency response, output capability (loci of maximum output power with frequency for 1dB gain compression (typical))

SL560

TYPICAL APPLICATIONS

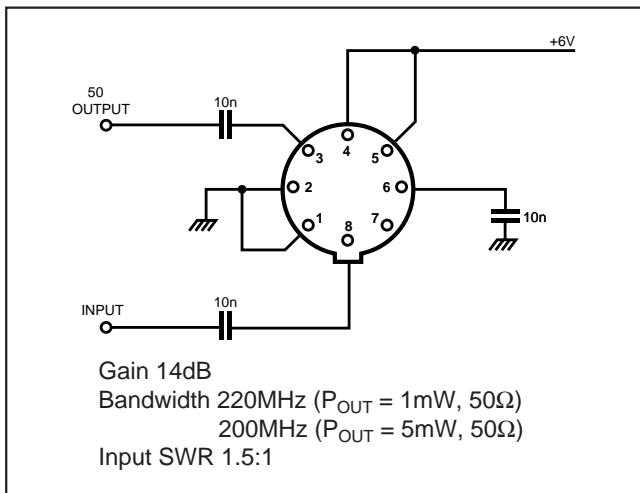

Fig.6 50Ω lin driver. The response of this configuration is shown in Fig.4

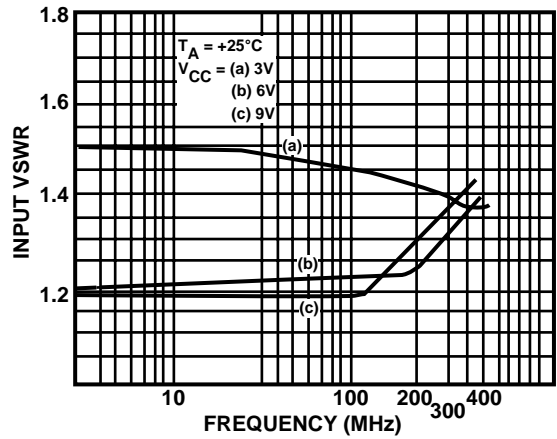

Fig.7 Input standing wave ratio plot of circuit shown in Fig.6 (typical)

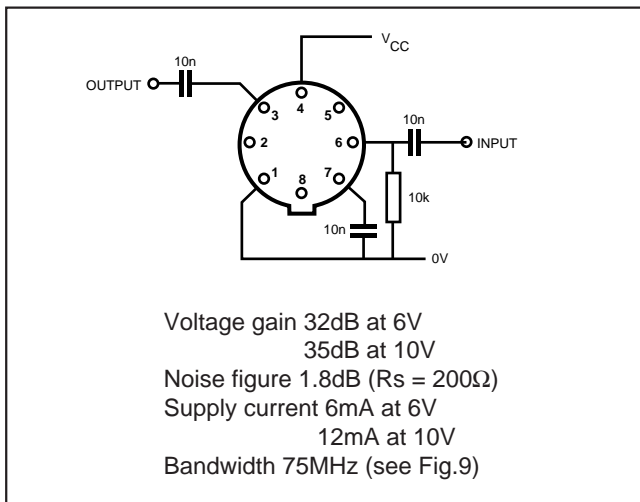

Fig.8 Low Noise preamplifier

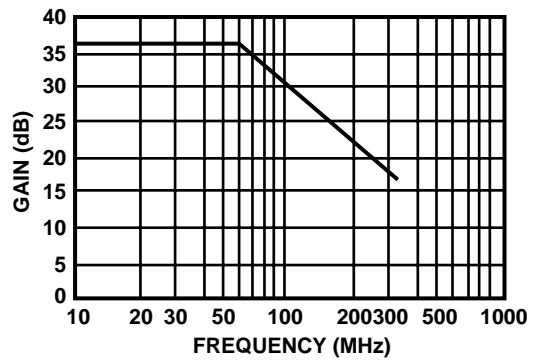

Fig.9 Frequency response of circuit shown in Fig.8 (typical)

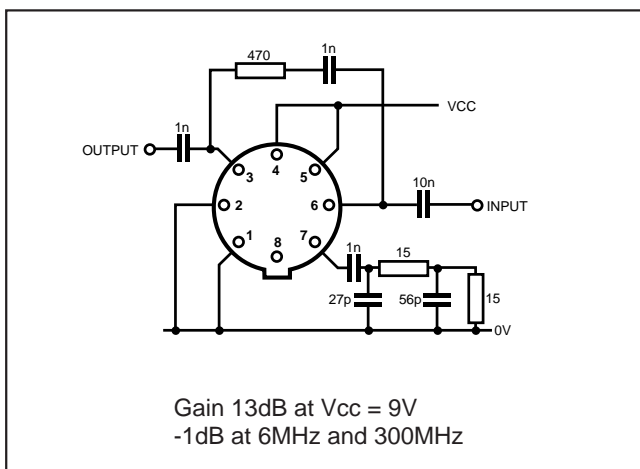

Fig.10 Wide bandwidth amplifier

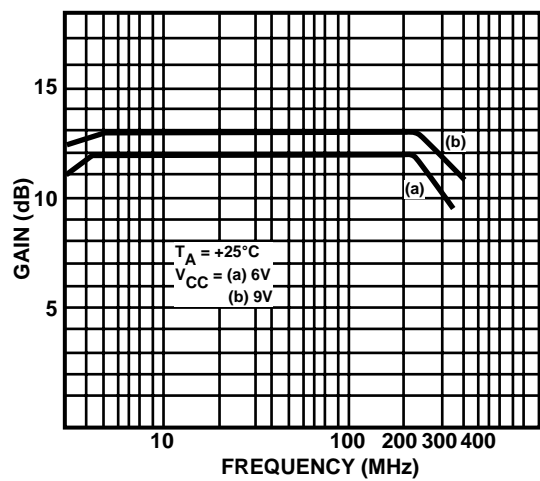

Fig.11 Frequency response of circuit shown in Fig.10 (typical)

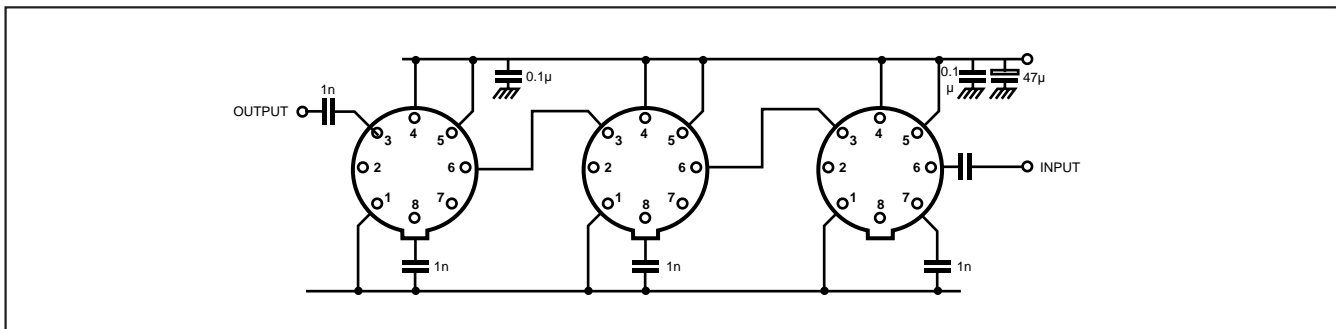

Fig.12 Three-stage directly-coupled high gain low noise amplifier

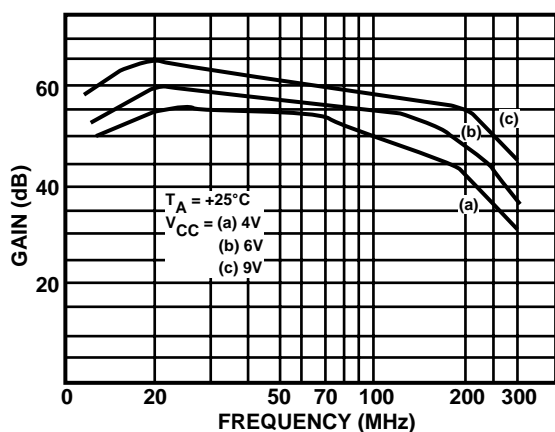

Fig.13 Frequency response of circuit shown in Fig.12 (typical)

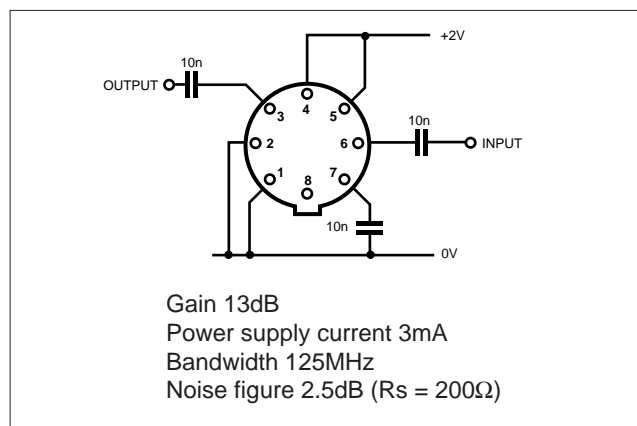

Fig.14 Low power consumption amplifier

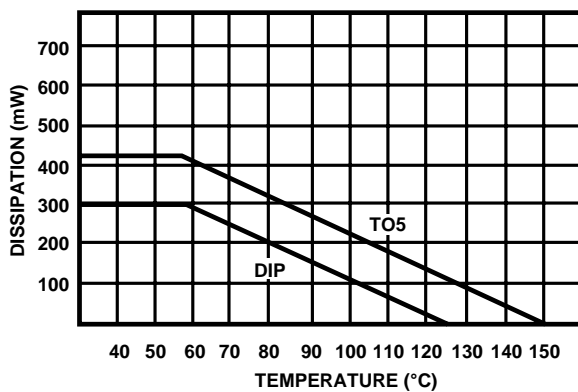

Fig.15 Ambient operating temperature V. degrees centigrade (typical)



HEADQUARTERS OPERATIONS
GEC PLESSEY SEMICONDUCTORS
Cheney Manor, Swindon,
Wiltshire SN2 2QW, United Kingdom.
Tel: (0793) 518000
Fax: (0793) 518411

GEC PLESSEY SEMICONDUCTORS
P.O. Box 660017
1500 Green Hills Road,
Scotts Valley, California 95067-0017,
United States of America.
Tel: (408) 438 2900
Fax: (408) 438 5576

CUSTOMER SERVICE CENTRES

- **FRANCE & BENELUX** Les Ulis Cedex Tel: (1) 64 46 23 45 Fax : (1) 64 46 06 07
- **GERMANY** Munich Tel: (089) 3609 06-0 Fax : (089) 3609 06-55
- **ITALY** Milan Tel: (02) 66040867 Fax: (02) 66040993
- **JAPAN** Tokyo Tel: (03) 5276-5501 Fax: (03) 5276-5510
- **NORTH AMERICA** Scotts Valley, USA Tel (408) 438 2900 Fax: (408) 438 7023.
- **SOUTH EAST ASIA** Singapore Tel: (65) 3827708 Fax: (65) 3828872
- **SWEDEN** Stockholm, Tel: 46 8 702 97 70 Fax: 46 8 640 47 36
- **UK, EIRE, DENMARK, FINLAND & NORWAY**
Swindon Tel: (0793) 518510 Fax : (0793) 518582

These are supported by Agents and Distributors in major countries world-wide.

© GEC Plessey Semiconductors 1994

This publication is issued to provide information only which (unless agreed by the Company in writing) may not be used, applied or reproduced for any purpose nor form part of any order or contract nor to be regarded as a representation relating to the products or services concerned. No warranty or guarantee express or implied is made regarding the capability, performance or suitability of any product or service. The Company reserves the right to alter without prior knowledge the specification, design or price of any product or service. Information concerning possible methods of use is provided as a guide only and does not constitute any guarantee that such methods of use will be satisfactory in a specific piece of equipment. It is the user's responsibility to fully determine the performance and suitability of any equipment using such information and to ensure that any publication or data used is up to date and has not been superseded. These products are not suitable for use in any medical products whose failure to perform may result in significant injury or death to the user. All products and materials are sold and services provided subject to the Company's conditions of sale, which are available on request.



**For more information about all Zarlink products
visit our Web Site at
www.zarlink.com**

Information relating to products and services furnished herein by Zarlink Semiconductor Inc. or its subsidiaries (collectively "Zarlink") is believed to be reliable. However, Zarlink assumes no liability for errors that may appear in this publication, or for liability otherwise arising from the application or use of any such information, product or service or for any infringement of patents or other intellectual property rights owned by third parties which may result from such application or use. Neither the supply of such information or purchase of product or service conveys any license, either express or implied, under patents or other intellectual property rights owned by Zarlink or licensed from third parties by Zarlink, whatsoever. Purchasers of products are also hereby notified that the use of product in certain ways or in combination with Zarlink, or non-Zarlink furnished goods or services may infringe patents or other intellectual property rights owned by Zarlink.

This publication is issued to provide information only and (unless agreed by Zarlink in writing) may not be used, applied or reproduced for any purpose nor form part of any order or contract nor to be regarded as a representation relating to the products or services concerned. The products, their specifications, services and other information appearing in this publication are subject to change by Zarlink without notice. No warranty or guarantee express or implied is made regarding the capability, performance or suitability of any product or service. Information concerning possible methods of use is provided as a guide only and does not constitute any guarantee that such methods of use will be satisfactory in a specific piece of equipment. It is the user's responsibility to fully determine the performance and suitability of any equipment using such information and to ensure that any publication or data used is up to date and has not been superseded. Manufacturing does not necessarily include testing of all functions or parameters. These products are not suitable for use in any medical products whose failure to perform may result in significant injury or death to the user. All products and materials are sold and services provided subject to Zarlink's conditions of sale which are available on request.

Purchase of Zarlink's I²C components conveys a licence under the Philips I²C Patent rights to use these components in and I²C System, provided that the system conforms to the I²C Standard Specification as defined by Philips.

Zarlink, ZL and the Zarlink Semiconductor logo are trademarks of Zarlink Semiconductor Inc.

Copyright Zarlink Semiconductor Inc. All Rights Reserved.

TECHNICAL DOCUMENTATION - NOT FOR RESALE
