

## REFLECTIVE SKANNERS

### Fiber Optic S51/S52 Series MINI-SKAN®

#### Features:

- Smallest Detectable Object: .011 in.
- Optimum Distance to Target: .030 in.
- Field of View: .033 in.
- Maximum Usable Distance: .100 in.
- Coaxial optical system
- Lamp, IR LED, or Visible Red LED Versions
- LED can be modulated
- Three body styles available
- High temperature tip



#### Description:

Light from the lamp or LED located in the back body is transmitted coaxially to the target through the outer ring of glass fibers in the threaded barrel. Light then reflects from the target back

through the inner fiber optic bundle to the photodetector in the backbody. This provides maximum light to dark contrast and the most efficient return of light to the sensor.

#### Typical Applications:

- For inspection and sorting
- Detecting semiconductors
- Encoders
- Small parts handling
- Accurate edge and position control
- Robotics

#### Specifications: (at 25°C)

##### LIGHT SOURCE—LAMP

Input 5.0 VDC, 115 mA

##### LIGHT SOURCE—IR LED

Input 100 mA max. with resultant voltage drop of 1.1 to 1.7 VDC; derate at 1 mA per degree above 25°C ambient

Modulated Input 1 A max., 10% duty cycle at 1 kHz min.

Reverse Voltage 2 V max.

Spectral Emission 940 nm peak

##### LIGHT SOURCE—VISIBLE RED LED

Input 50 mA max. with resultant voltage drop of 1.8 VDC typical; derate at 1 mA per degree above 25°C ambient

Modulated Input 80 mA max., 50% duty cycle at 1 kHz min.

Reverse Voltage 4 V max.

Spectral Emission 660 nm peak

##### PHOTODETECTOR

Operating Voltage 20 VDC max.

Response Time See Response Time Chart under *Technical Information*

Spectral Response 910 nm peak

FILTER (optional) Transmits less than 5% at 700 nm and less than 0.1% at 600 nm

BODY Aluminum, black for lamp units, red for IR and visible red LED units. Passivated brass barrel

TEMPERATURE Operating: Body 0° to 50°C

Tip: -40° to 125°C

Storage: -40° to 50°C

LEADS 4 cond. 26 AWG., teflon covered cable with shielded photodetector leads and overall shield, 6 ft. long, Type J (Shielded Quad)



## S51/S52 Series

### Dimensions:

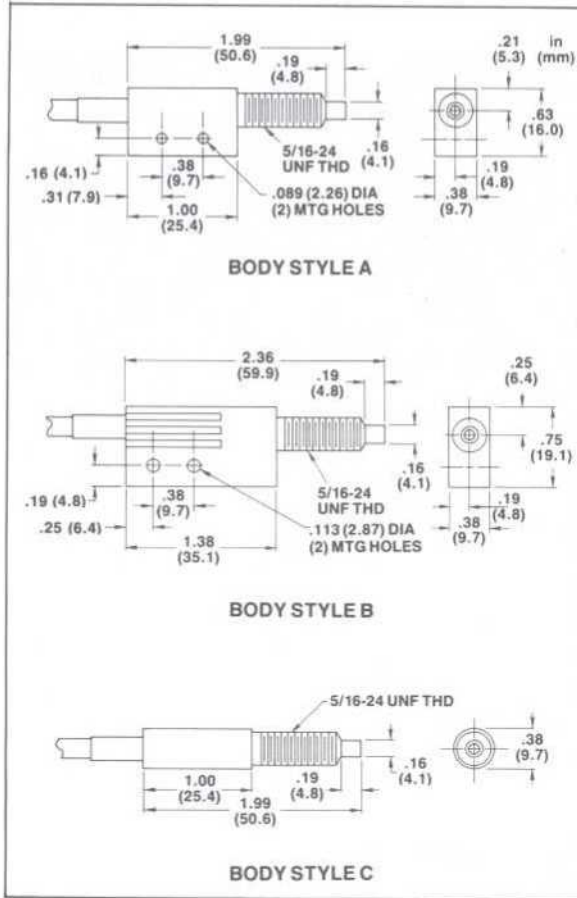

### Typical Performance Chart:

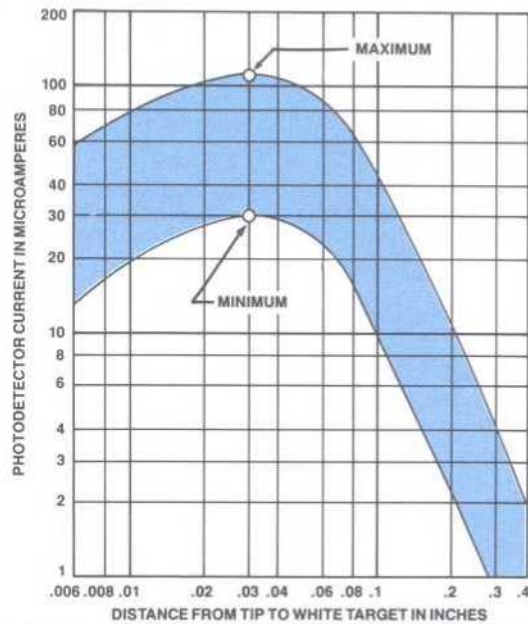
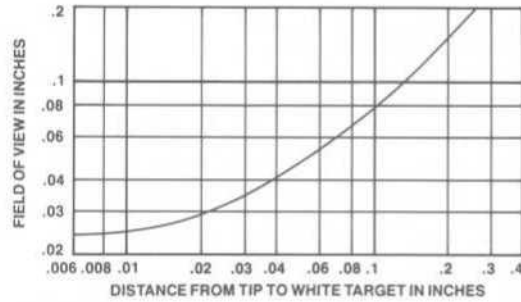

Circles indicate guaranteed test limits. See Quality Control under Technical Information, pg. 16.

### Compatibility With Controls:

The S51 and S52 Series are compatible with all Skan-A-Matic controls except modulating controls which are used with LED skanners only. For high speed operation use the T41300 High Speed Amplifier.

The IR LED versions of this series utilize a 100 mA Light Emitting Diode. A 39 ohm, 1 W current limiting resistor is supplied and must be used with Skan-A-Matic controls furnishing 5 VDC for light source power. With modulating controls such as our R42/T42 and R43/T43, no current limiting resistor is used.

The visible red LED versions of this series utilize a 50 mA Light Emitting diode. A 68 ohm, 1/2 W current limiting resistor is supplied and must be used with Skan-A-Matic controls furnishing 5 VDC for light source power. With modulating controls such as our R42/T42 and R43/T43, a 6.8 ohm, 1/4 W current limiting resistor must be used.



## S51/S52 Series

### Model Selection Guide:

Part #	Light Source	Body Style	Filter
S51101	Lamp	A	No
S51105	Lamp	A	Yes
S51104	IR LED	B	No
S51106	IR LED	B	Yes
S51108	Visible red LED	B	No
S52101	Lamp	C	No
S52105	Lamp	C	Yes

### Variations:

#### LEADS

Extra lead lengths available. See pg. 129.

#### Options:

##### COIL CORD

Four conductor, 28 gauge, coil cord with shield available in 10 ft. (fully extended) or 20 ft. (fully extended) lengths — see pg. 129.

##### PROTECTIVE SHEATH

Can be factory installed over standard Type J lead (Shielded Quad). Order by adding the suffix as follows:

- M For square locked galvanized steel with black PVC jacket, 9/32" O.D. Example: S51101-M
- S For square locked stainless steel armor, 3/16" O.D. Example: S51101-S

##### CONNECTOR

The S51 and S52 Series skanners are available with connector installed. The mating half is furnished for field connection. Order by adding a suffix as follows:

- P For connector pair with in-line receptacle. Example: S51101-P
- F For connector pair with flanged, panel-mount receptacle. Example: S51101-F

See *Options* for a more detailed description.

### Wiring Diagram:

