

RS-545SH

OUTPUT : 5.0W ~ 75W (APPROX)

カーボンブラシ | Carbon-brush motors | 碳精电刷

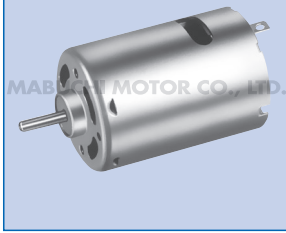

代表的用途 家電機器：ヘアードライヤー／マッサージャー／バイブレーター／バキュームクリーナー／給排水ポンプ

Typical Applications Home Appliances : Hair Dryer / Massager / Vibrator / Vacuum Cleaner / Bilge Pump

主要用途 家电机器：吹风机、按摩棒、真空吸尘器、给排水泵

WEIGHT : 156g (APPROX)

MODEL	VOLTAGE		NO LOAD		AT MAXIMUM EFFICIENCY				STALL			
	OPERATING RANGE	NOMINAL	SPEED	CURRENT	SPEED	CURRENT	TORQUE	OUTPUT	TORQUE	CURRENT		
			r/min	A	r/min	A	mN·m	g·cm	W	mN·m	g·cm	A
RS-545SH-18150	12~32	24V CONSTANT	5300	0.10	4390	0.48	15.2	155	6.97	88.3	900	2.32
RS-545SH-2860	6~24	12V CONSTANT	6800	0.25	5730	1.34	17.3	176	10.4	110	1121	7.20

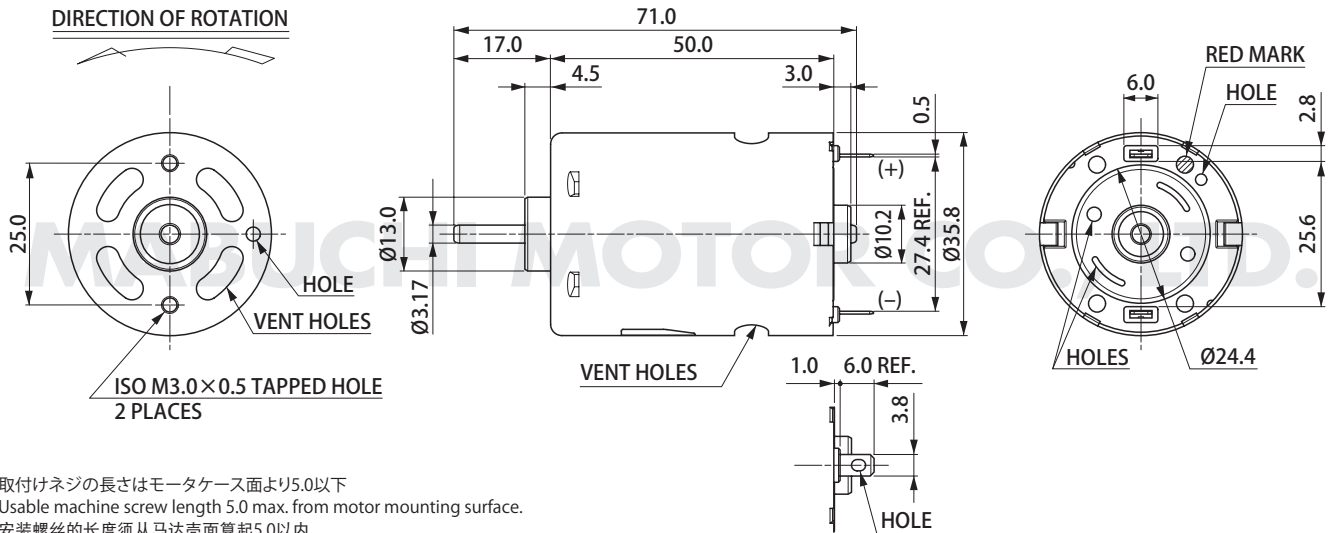

取付けネジの長さはモータケース面より5.0以下
Usable machine screw length 5.0 max. from motor mounting surface.
安装螺丝的长度须从马达壳面算起5.0以内

RS-545SH-18150 24.0V

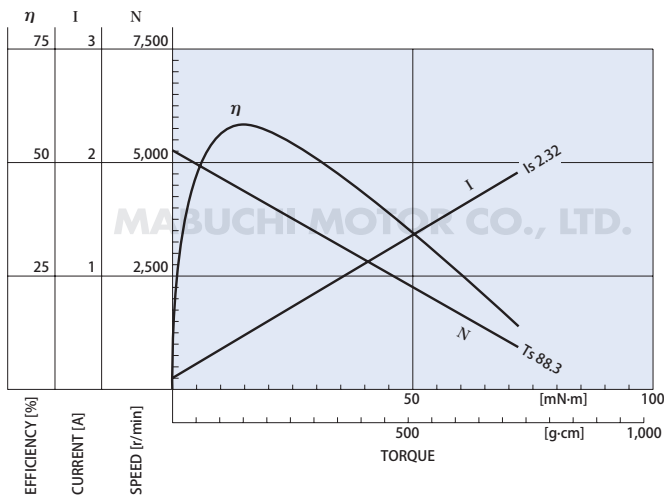

RS-545SH-2860 12.0V

