



PS600R~PS608R

FAST SWITCHING RECTIFIERS

VOLTAGE 50 to 800 Volts **CURRENT** 6.0 Amperes

P-600

Unit: inch(mm)

FEATURES

- Plastic package has Underwriters Laboratory Flammability Classification 94V-O utilizing Flame Retardant Epoxy Molding Compound.
- Glass passivated junction in P600 package.
- Exceeds environmental standards of MIL-S-19500/228
- 6 ampere operation at $T_A=60^\circ\text{C}$ with no thermal runaway.
- Fast switching for high efficiency.
- In compliance with EU RoHS 2002/95/EC directives

MECHANICAL DATA

- Case: Molded plastic, P600
- Terminals: Axial leads, solderable to MIL-STD-750, Method 2026
- Polarity: Color Band denotes cathode end
- Mounting Position: Any
- Weight: 0.0719 ounce, 2.04 gram

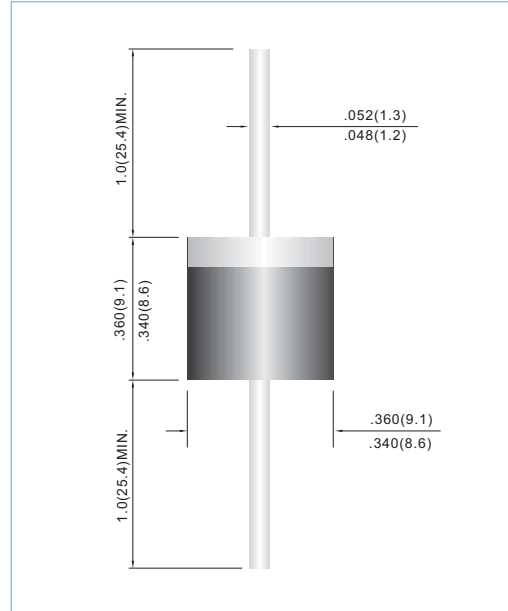

MAXIMUM RATINGS AND ELECTRICAL CHARACTERISTICS

Ratings at 25°C ambient temperature unless otherwise specified.
Resistive or inductive load, 60Hz.

PARAMETER	SYMBOL	PS600R	PS601R	PS602R	PS604R	PS606R	PS608R	UNITS
Maximum Recurrent Peak Reverse Voltage	V_{RRM}	50	100	200	400	600	800	V
Maximum RMS Voltage	V_{RMS}	35	70	140	280	420	560	V
Maximum DC Blocking Voltage	V_{DC}	50	100	200	400	600	800	V
Maximum Average Forward Current .375" (9.5mm) lead length at $T_A=60^\circ\text{C}$	$I_{F(AV)}$	6.0						A
Peak Forward Surge Current : IFM (surge): 8.3ms single half sine-wave superimposed on rated load (JEDEC method)	I_{FSM}	300						A
Maximum Forward Voltage at 6.0A	V_F	1.3						V
Maximum Full Load Reverse Current Full Cycle Average at $T_J=25^\circ\text{C}$ Maximum DC Reverse Current at Rated DC Blocking Voltage $T_J=100^\circ\text{C}$	I_R	10.0 500						μA
Maximum Reverse Recovery Time (Note 1)	t_{rr}	150				250	500	ns
Typical Junction capacitance (Note 2)	C_J	300						pF
Typical Junction Resistance at .375" (9.5mm) lead length	$R_{\theta JA}$	10						$^\circ\text{C} / \text{W}$
Operating and Storage Temperature Range	T_J, T_{STG}	-50 to +150						$^\circ\text{C}$

NOTES: 1. Reverse Recovery Test Conditions: $I_F=5\text{A}$, $I_R=1\text{A}$, $I_{rr}=25\text{A}$
2. Measured at 1 MHz and applied reverse voltage of 4.0 VDC



PS600R~PS608R

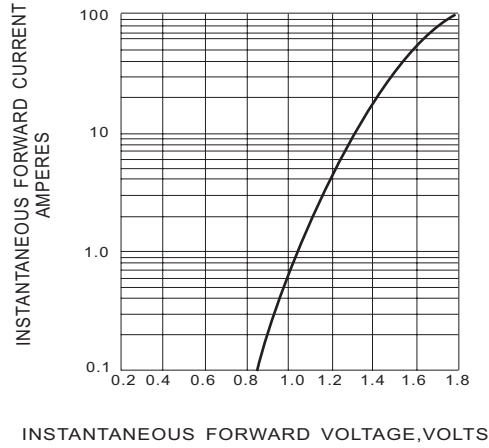

Fig.1-FORWARD CHARACTERISTICS

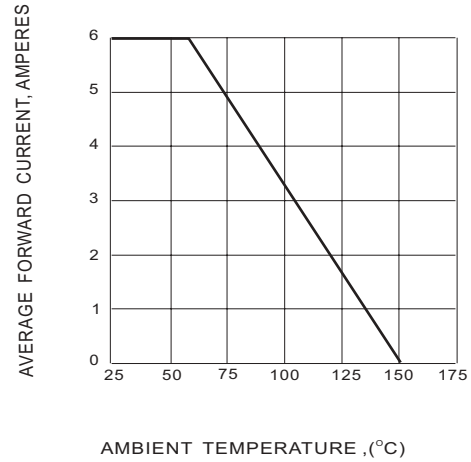

Fig.2-FORWARD CURRENT DERATING CURVE

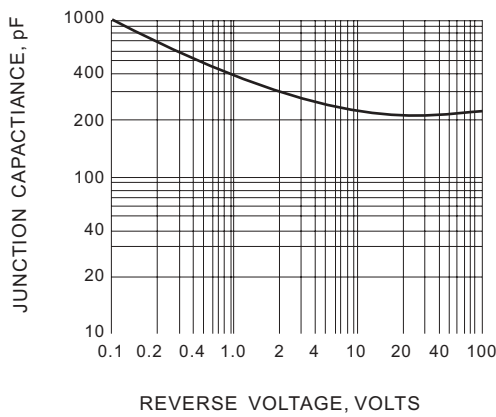

Fig.3-TYPICAL JUNCTION CAPACITANCE

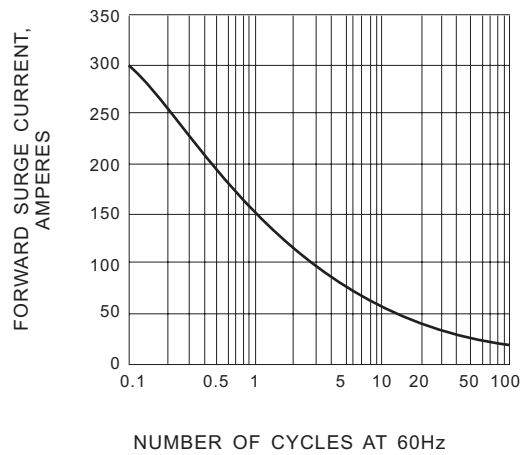

Fig.4-PEAK FORWARD SURGE CURRENT

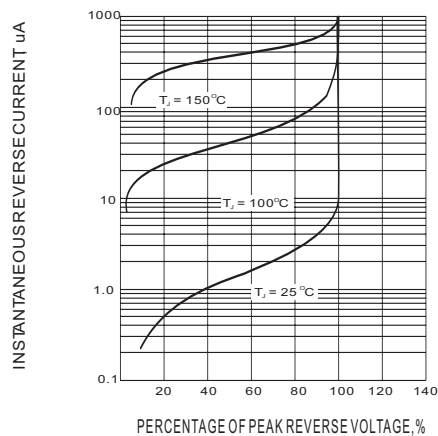

Fig.5- TYPICAL REVERSE CHARACTERISTIC