



# M54HCT244

## RAD HARD OCTAL BUS BUFFER WITH 3 STATE OUTPUTS (NON INVERTED)

- HIGH SPEED:  
 $t_{PD} = 15 \text{ ns (TYP.)}$  at  $V_{CC} = 4.5V$
- LOW POWER DISSIPATION:  
 $I_{CC} = 4\mu A(\text{MAX.})$  at  $T_A = 25^\circ C$
- COMPATIBLE WITH TTL OUTPUTS:  
 $V_{IH} = 2V (\text{MIN.})$   $V_{IL} = 0.8V (\text{MAX})$
- BALANCED PROPAGATION DELAYS:  
 $t_{PLH} \cong t_{PHL}$
- SYMMETRICAL OUTPUT IMPEDANCE:  
 $|I_{OH}| = I_{OL} = 6mA (\text{MIN})$
- PIN AND FUNCTION COMPATIBLE WITH 54 SERIES 244
- SPACE GRADE-1: ESA SCC QUALIFIED
- 50 krad QUALIFIED, 100 krad AVAILABLE ON REQUEST
- NO SEL UNDER HIGH LET HEAVY IONS IRRADIATION
- DEVICE FULLY COMPLIANT WITH SCC-9402-009

### DESCRIPTION

The 54HCT244 is an advanced high-speed CMOS OCTAL BUS BUFFER (3-STATE) fabricated with silicon gate C<sup>2</sup>MOS technology.

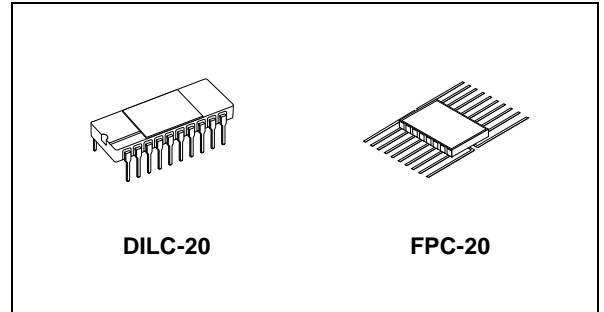

### ORDER CODES

PACKAGE	FM	EM
DILC	M54HCT244D	M54HCT244D1
FPC	M54HCT244K	M54HCT244K1

$\overline{G}$  control input governs four BUS BUFFERs.  
All inputs are equipped with protection circuits against static discharge and transient excess voltage.

### PIN CONNECTION

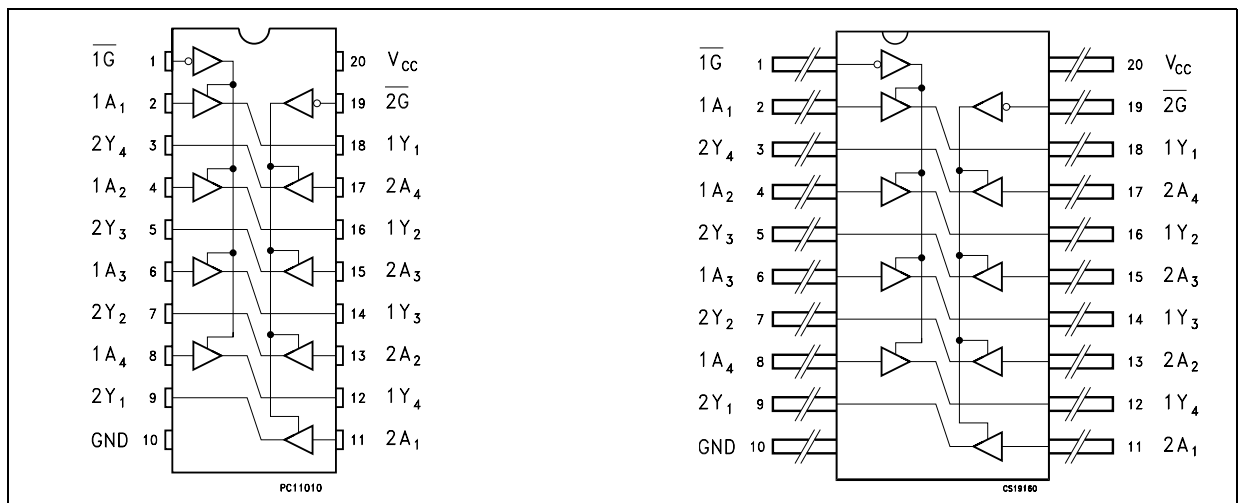

Figure 1: IEC Logic Symbols

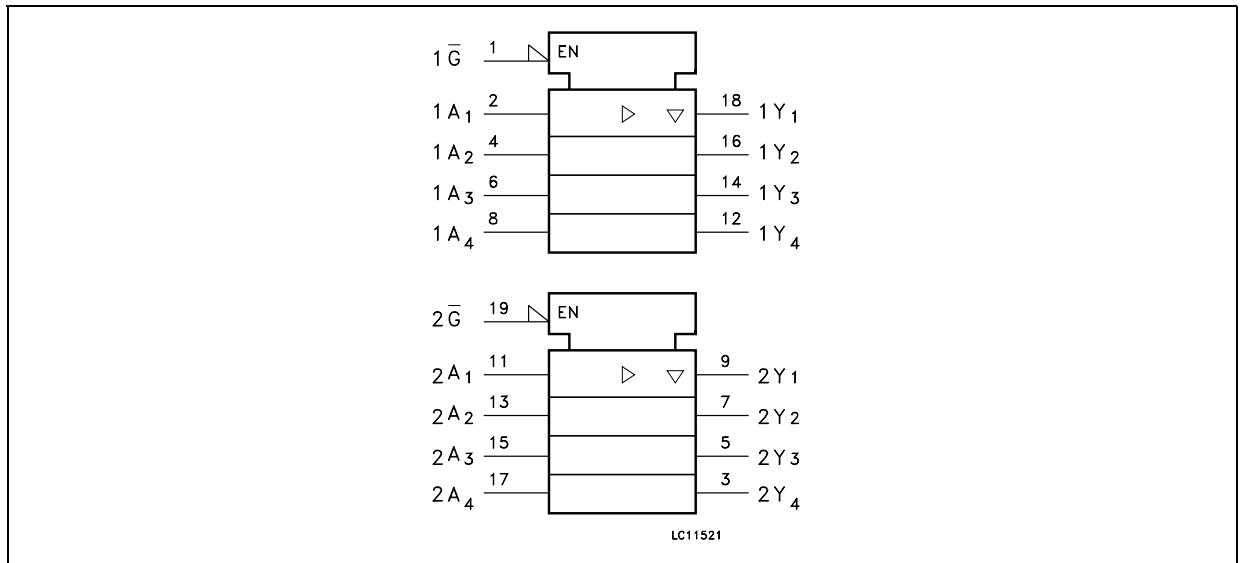

Figure 2: Input And Output Equivalent Circuit

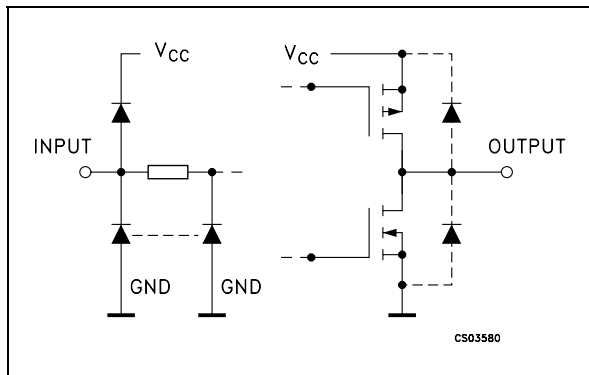

Table 1: Pin Description

PIN N°	SYMBOL	NAME AND FUNCTION
1	1G	Output Enable Input
2, 4, 6, 8	1A1 to 1A4	Data Inputs
9, 7, 5, 3	2Y1 to 2Y4	Data Outputs
11, 13, 15, 17	2A1 to 2A4	Data Inputs
18, 16, 14, 12	1Y1 to 1Y4	Data Outputs
19	2G	Output Enable Input
10	GND	Ground (0V)
20	V <sub>CC</sub>	Positive Supply Voltage

Table 2: Truth Table

INPUTS		OUTPUT
$\bar{G}$	A <sub>n</sub>	Y <sub>n</sub>
L	L	L
L	H	H
H	X	Z

X : Don't Care  
Z : High Impedance

**Table 3: Absolute Maximum Ratings**

Symbol	Parameter	Value	Unit
$V_{CC}$	Supply Voltage	-0.5 to +7	V
$V_I$	DC Input Voltage	-0.5 to $V_{CC} + 0.5$	V
$V_O$	DC Output Voltage	-0.5 to $V_{CC} + 0.5$	V
$I_{IK}$	DC Input Diode Current	$\pm 20$	mA
$I_{OK}$	DC Output Diode Current	$\pm 20$	mA
$I_O$	DC Output Current	$\pm 35$	mA
$I_{CC}$ or $I_{GND}$	DC $V_{CC}$ or Ground Current	$\pm 70$	mA
$P_D$	Power Dissipation	420	mW
$T_{stg}$	Storage Temperature	-65 to +150	°C
$T_L$	Lead Temperature (10 sec)	265	°C

Absolute Maximum Ratings are those values beyond which damage to the device may occur. Functional operation under these conditions is not implied

**Table 4: Recommended Operating Conditions**

Symbol	Parameter	Value	Unit
$V_{CC}$	Supply Voltage	4.5 to 5.5	V
$V_I$	Input Voltage	0 to $V_{CC}$	V
$V_O$	Output Voltage	0 to $V_{CC}$	V
$T_{op}$	Operating Temperature	-55 to 125	°C
$t_r, t_f$	Input Rise and Fall Time ( $V_{CC} = 4.5$ to $5.5V$ )	0 to 500	ns

Table 5: DC Specifications

Symbol	Parameter	Test Condition		Value						Unit	
		V <sub>CC</sub> (V)		T <sub>A</sub> = 25°C			-40 to 85°C		-55 to 125°C		
				Min.	Typ.	Max.	Min.	Max.	Min.		Max.
V <sub>IH</sub>	High Level Input Voltage	4.5 to 5.5		2.0			2.0		2.0		V
V <sub>IL</sub>	Low Level Input Voltage	4.5 to 5.5				0.8		0.8		0.8	V
V <sub>OH</sub>	High Level Output Voltage	4.5	I <sub>O</sub> =-20 μA	4.4	4.5		4.4		4.4		V
			I <sub>O</sub> =-6.0 mA	4.18	4.31		4.13		4.10		
V <sub>OL</sub>	Low Level Output Voltage	4.5	I <sub>O</sub> =20 μA		0.0	0.1		0.1		0.1	V
			I <sub>O</sub> =6.0 mA		0.17	0.26		0.33		0.40	
I <sub>I</sub>	Input Leakage Current	5.5	V <sub>I</sub> = V <sub>CC</sub> or GND			± 0.1		± 1		± 1	μA
I <sub>OZ</sub>	High Impedance Output Leakage Current	5.5	V <sub>I</sub> = V <sub>IH</sub> or V <sub>IL</sub> V <sub>O</sub> = V <sub>CC</sub> or GND			± 0.5		± 5		± 10	μA
I <sub>CC</sub>	Quiescent Supply Current	5.5	V <sub>I</sub> = V <sub>CC</sub> or GND			4		40		80	μA
Δ I <sub>CC</sub>	Additional Worst Case Supply Current	5.5	Per Input pin V <sub>I</sub> = 0.5V or V <sub>I</sub> = 2.4V Other Inputs at V <sub>CC</sub> or GND			2.0		2.9		3.0	mA

Table 6: AC Electrical Characteristics (C<sub>L</sub> = 50 pF, Input t<sub>r</sub> = t<sub>f</sub> = 6ns)

Symbol	Parameter	Test Condition		Value						Unit		
		V <sub>CC</sub> (V)	C <sub>L</sub> (pF)		T <sub>A</sub> = 25°C			-40 to 85°C			-55 to 125°C	
					Min.	Typ.	Max.	Min.	Max.		Min.	Max.
t <sub>TLH</sub> t <sub>THL</sub>	Output Transition Time	4.5	50		7	12		15		18	ns	
t <sub>PLH</sub> t <sub>PHL</sub>	Propagation Delay Time	4.5	50		15	22		28		33	ns	
		4.5	150		21	30		38		45		
t <sub>PLH</sub> t <sub>PHL</sub>	Propagation Delay Time	4.5	50		15	25		31		38	ns	
		4.5	150		21	33		41		50		
t <sub>PZL</sub> t <sub>PZH</sub>	Output Enable Time	4.5	50	R <sub>L</sub> = 1 KΩ	17	30		38		45	ns	
		4.5	150		23	38		48		57		
t <sub>PLZ</sub> t <sub>PHZ</sub>	Output Disable Time	4.5	50	R <sub>L</sub> = 1 KΩ	16	30		38		45	ns	

Table 7: Capacitive Characteristics

Symbol	Parameter	Test Condition		Value						Unit	
		V <sub>CC</sub> (V)		T <sub>A</sub> = 25°C			-40 to 85°C		-55 to 125°C		
				Min.	Typ.	Max.	Min.	Max.	Min.		Max.
C <sub>IN</sub>	Input Capacitance				5	10		10		10	pF
C <sub>OUT</sub>	Output Capacitance				10						pF
C <sub>PD</sub>	Power Dissipation Capacitance (note 1)				31						pF

1) C<sub>PD</sub> is defined as the value of the IC's internal equivalent capacitance which is calculated from the operating current consumption without load. (Refer to Test Circuit). Average operating current can be obtained by the following equation.  $I_{CC(opr)} = C_{PD} \times V_{CC} \times f_{IN} + I_{CC}/8$  (per circuit)

Table 8: Test Circuit

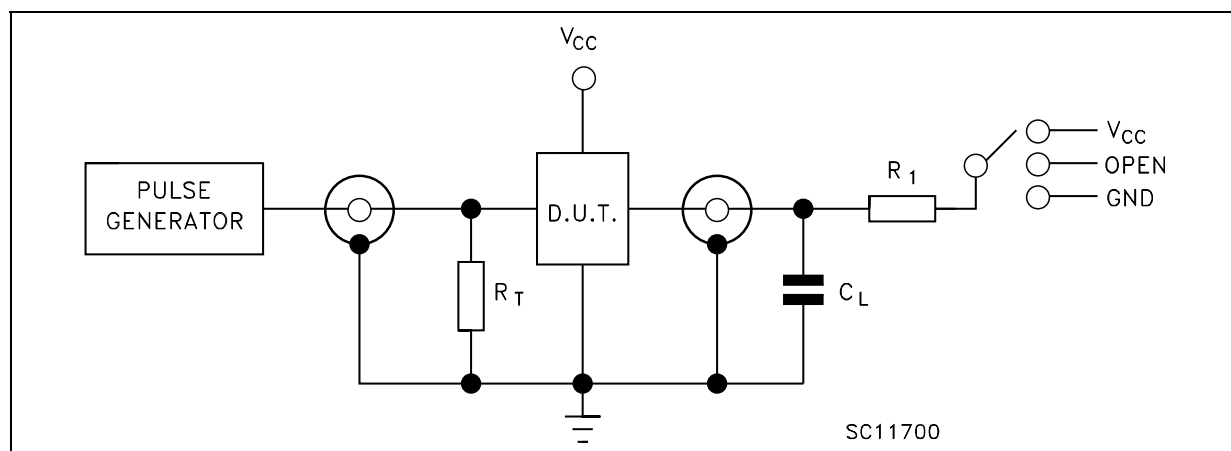

TEST	SWITCH
t <sub>PLH</sub> , t <sub>PHL</sub>	Open
t <sub>PZL</sub> , t <sub>PLZ</sub>	V <sub>CC</sub>
t <sub>PZH</sub> , t <sub>PHZ</sub>	GND

C<sub>L</sub> = 50pF/150pF or equivalent (includes jig and probe capacitance)

R<sub>1</sub> = 1KΩ or equivalent

R<sub>T</sub> = Z<sub>OUT</sub> of pulse generator (typically 50Ω)

Figure 3: Waveform - Propagation Delay Times (f=1MHz; 50% duty cycle)

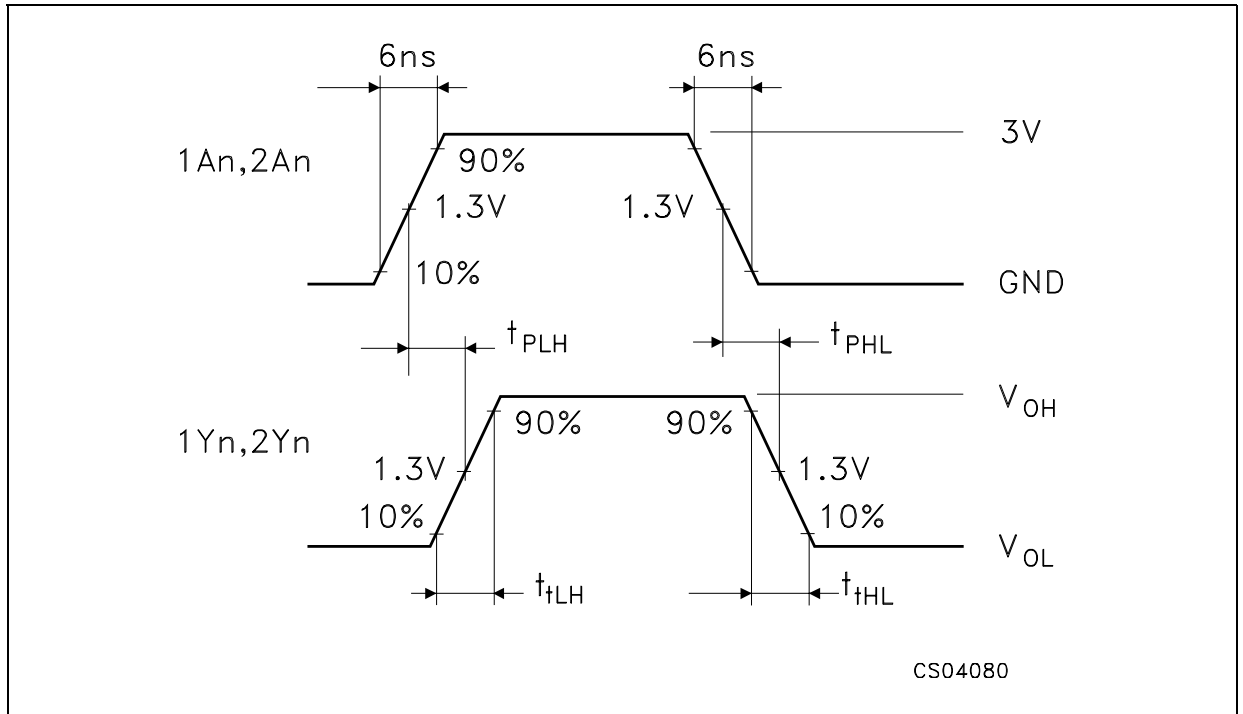
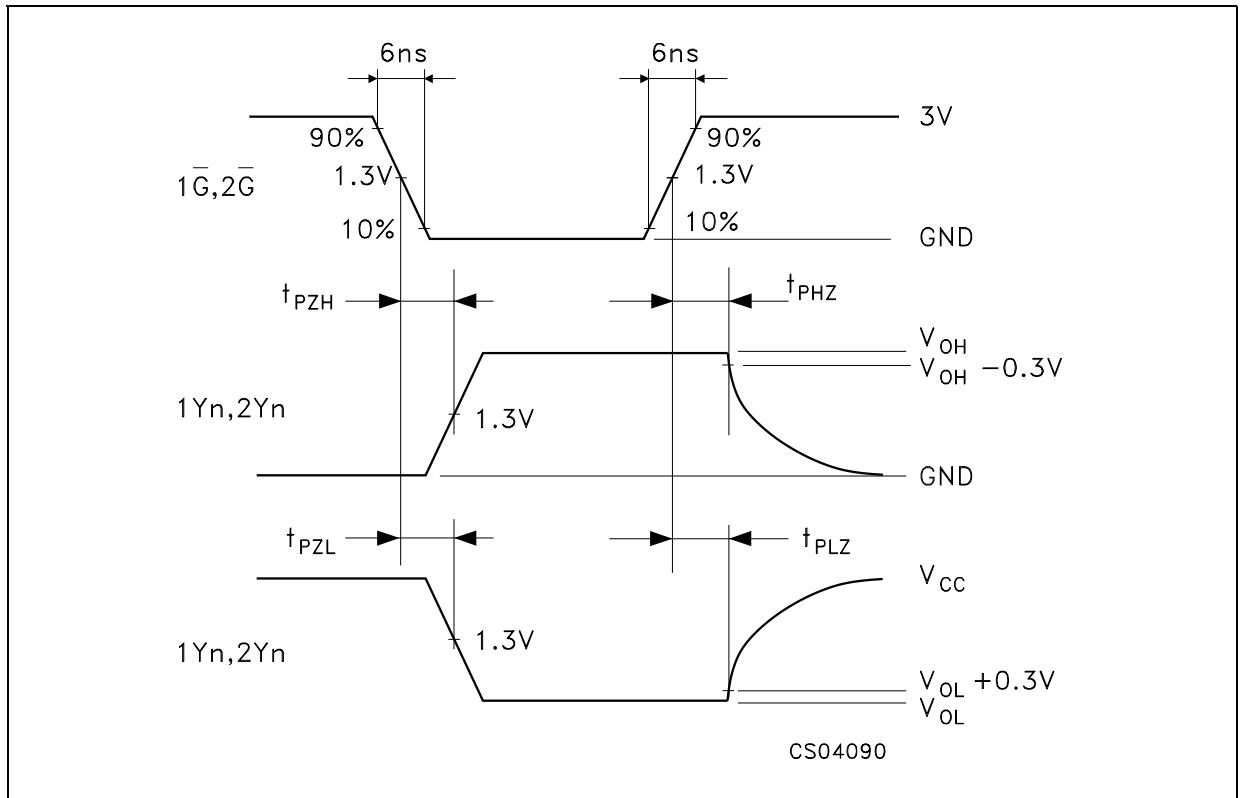
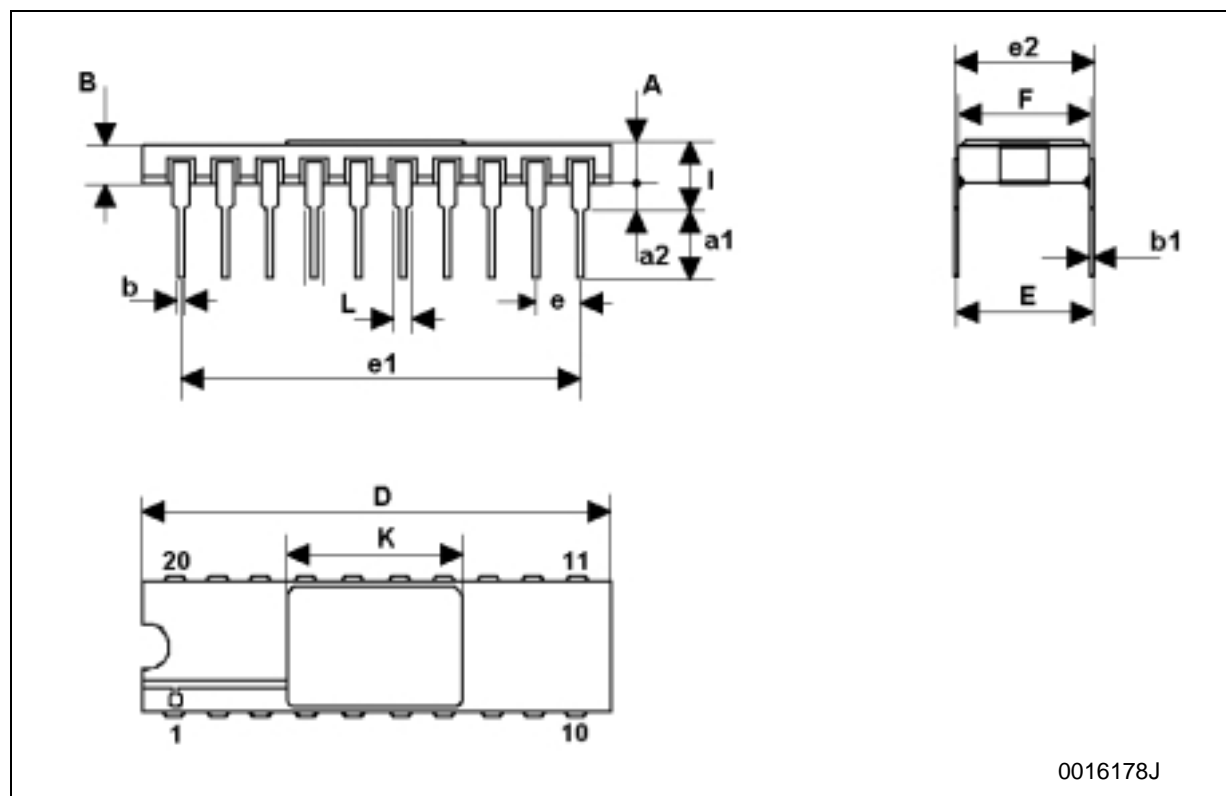

Figure 4: Waveform - Output And Enable Times (f=1MHz; 50% duty cycle)



## DILC-20 MECHANICAL DATA

DIM.	mm.			inch		
	MIN.	TYP	MAX.	MIN.	TYP.	MAX.
A	2.1		2.71	0.083		0.107
a1	3.00		3.70	0.118		0.146
a2	0.63	0.88	1.14	0.025	0.035	0.045
B	1.93	2.03	2.23	0.076	0.080	0.088
b	0.40	0.45	0.50	0.016	0.018	0.020
b1	0.20	0.254	0.30	0.008	0.010	0.012
D	25.14	25.40	25.65	0.990	1.000	1.010
E	7.36	7.62	7.87	0.290	0.300	0.310
e		2.54			0.100	
e1	22.73	22.86	22.99	0.895	0.900	0.905
e2	7.62	7.87	8.12	0.300	0.310	0.320
F	7.29	7.49	7.70	0.287	0.295	0.303
I			3.86			0.152
K	11.30		11.56	0.445		0.455
L	1.14	1.27	1.40	0.045	0.050	0.055



0016178J

## FPC-20 MECHANICAL DATA

DIM.	mm.			inch		
	MIN.	TYP	MAX.	MIN.	TYP.	MAX.
A	9.98	10.16	10.34	0.393	0.400	0.407
B	9.98	10.16	10.34	0.393	0.400	0.407
C	1.45	1.61	1.78	0.57	0.63	0.070
D	0.10	0.127	0.18	0.004	0.005	0.007
E	11.30	11.43	11.56	0.445	0.450	0.455
F		1.27			0.050	
G	0.38	0.43	0.48	0.015	0.017	0.019
H	7.24		8.16	0.285		0.320
L	24.46		26.67	0.960		1.050
M	0.45	0.50	0.55	0.018	0.020	0.022
N		7.87			0.310	
O	1.14	1.27	1.40	0.045	0.050	0.055
P	0.10	0.18	0.25	0.004	0.007	0.010

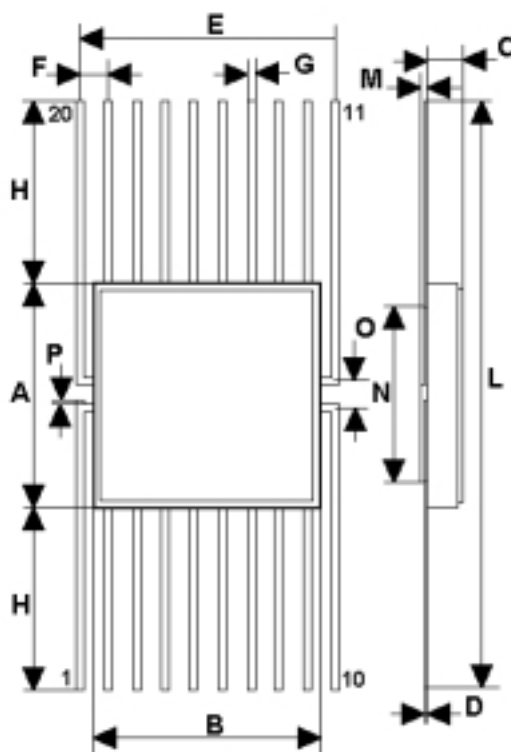

016032F



**Table 9: Revision History**

Date	Revision	Description of Changes
15-Jun-2004	1	First Release

Information furnished is believed to be accurate and reliable. However, STMicroelectronics assumes no responsibility for the consequences of use of such information nor for any infringement of patents or other rights of third parties which may result from its use. No license is granted by implication or otherwise under any patent or patent rights of STMicroelectronics. Specifications mentioned in this publication are subject to change without notice. This publication supersedes and replaces all information previously supplied. STMicroelectronics products are not authorized for use as critical components in life support devices or systems without express written approval of STMicroelectronics.

The ST logo is a registered trademark of STMicroelectronics  
All other names are the property of their respective owners

© 2004 STMicroelectronics - All Rights Reserved  
STMicroelectronics GROUP OF COMPANIES

Australia - Belgium - Brazil - Canada - China - Czech Republic - Finland - France - Germany - Hong Kong - India - Israel - Italy - Japan -  
Malaysia - Malta - Morocco - Singapore - Spain - Sweden - Switzerland - United Kingdom - United States.

<http://www.st.com>