

# LM140QML

## Three Terminal Positive Regulators

### General Description

The monolithic 3-terminal positive voltage regulators employ internal current-limiting, thermal shutdown and safe-area compensation, making them essentially indestructible. If adequate heat sinking is provided, they can deliver over 0.5A output current. They are intended as fixed voltage regulators in a wide range of applications including local (on-card) regulation for elimination of noise and distribution problems associated with single-point regulation. In addition to use as fixed voltage regulators, these devices can be used with external components to obtain adjustable output voltages and currents.

Considerable effort was expended to make the entire series of regulators easy to use and minimize the number of external

components. It is not necessary to bypass the output, although this does improve transient response. Input bypassing is needed only if the regulator is located far from the filter capacitor of the power supply.

### Features

- Complete specifications at 1.0A and 0.5A loads
- No external components
- Internal thermal overload protection
- Internal short circuit current-limiting
- Output transistor safe-area compensation

### Ordering Information

NS Part Number	SMD Part Number	NS Package Number	Package Description
LM140H-5.0/883		H03A	3LD TO-39 Metal Can
LM140H-12/883		H03A	3LD TO-39 Metal Can
LM140H-15/883		H03A	3LD TO-39 Metal Can
LM140K-5.0/883		K02C	2LD TO-3 Metal Can
LM140K-12/883		K02C	2LD TO-3 Metal Can
LM140K-15/883		K02C	2LD TO-3 Metal Can

### Connection Diagrams

Steel Metal Can TO-39 Package (H)

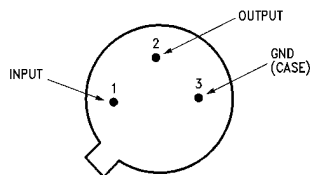

20155401  
**Bottom View**  
 See NS Package Number H03A

TO-3 Metal Can (K)

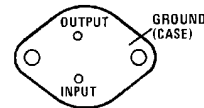

20155402  
**Bottom View**  
 See NS Package Number K02C

## Absolute Maximum Ratings (Note 1)

DC Input Voltage	35V
Internal Power Dissipation (Note 2)	Internally Limited
Maximum Junction Temperature ( $T_{Jmax}$ )	150°C
Storage Temperature Range	$-65^{\circ}\text{C} \leq T_A \leq +150^{\circ}\text{C}$
Operating Temperature Range	$-55^{\circ}\text{C} \leq T_A \leq +125^{\circ}\text{C}$
Lead Temperature (Soldering 10 seconds)	300°C
Thermal Resistance	
$\theta_{JA}$	
T0-39 (Still Air)	232°C/W
T0-39 (500 LF/Min Air Flow)	77°C/W
T0-3 (Still Air)	35°C/W
T0-3 (500 LF/Min Air Flow)	TBD
$\theta_{JC}$	
T0-39	15°C/W
T0-3	4°C/W
ESD Susceptibility (Note 3)	2KV

## Quality Conformance Inspection

MIL-Std-883, Method 5005 - Group A

Subgroup	Description	Temp °C
1	Static tests at	+25
2	Static tests at	+125
3	Static tests at	-55
4	Dynamic tests at	+25
5	Dynamic tests at	+125
6	Dynamic tests at	-55
7	Functional tests at	+25
8A	Functional tests at	+125
8B	Functional tests at	-55
9	Switching tests at	+25
10	Switching tests at	+125
11	Switching tests at	-55
12	Settling time at	+25
13	Settling time at	+125
14	Settling time at	-55

## LM140H–5.0 Electrical Characteristics

### DC Parameters

The following conditions apply, unless otherwise specified.

DC:  $V_I = 10V$ ,  $I_L = 350mA$

Symbol	Parameter	Conditions	Notes	Min	Max	Unit	Sub-groups
$V_O$	Output Voltage	$V_I = 35V$ , $I_L = 5mA$		4.75	5.75	V	1
				4.80	5.20	V	1
		$V_I = 8V$		4.70	5.30	V	1, 2, 3
		$V_I = 8V$ , $I_L = 5mA$		4.70	5.30	V	1, 2, 3
		$V_I = 20V$ , $I_L = 5mA$		4.70	5.30	V	1, 2, 3
		$V_I = 20V$		4.70	5.30	V	1, 2, 3
$R_{Line}$	Line Regulation	$7V \leq V_I \leq 25V$ , $I_L = 200mA$		-50	50	mV	1
		$8V \leq V_I \leq 25V$ , $I_L = 200mA$		-50	50	mV	2, 3
		$8V \leq V_I \leq 20V$ , $I_L = 200mA$		-25	25	mV	1
				-40	40	mV	2, 3
$R_{Load}$	Load Regulation	$5mA \leq I_L \leq 500mA$		-50	50	mV	1
				-100	100	mV	2, 3
		$5mA \leq I_L \leq 200mA$		-25	25	mV	1
				-50	50	mV	2, 3
$I_Q$	Quiescent Current				7.0	mA	1, 2, 3
$\Delta I_Q$	Quiescent Current Change	$8V \leq V_I \leq 25V$ , $I_L = 200mA$		-0.8	0.8	mA	1, 2, 3
		$5mA \leq I_L \leq 350mA$		-0.5	0.5	mA	1, 2, 3
$I_{Pk}$	Peak Current	$V_I - V_O = 7V$	(Note 4)	0.4	2.0	A	1, 2, 3
$V_{DO}$	Dropout Voltage		(Note 5)		2.5	V	1
$I_{OS}$	Short Circuit Current	$V_I = 35V$			1.0	A	1, 2, 3

### AC Parameters

The following conditions apply, unless otherwise specified.

AC:  $V_I = 10V$ ,  $I_L = 350mA$

Symbol	Parameter	Conditions	Notes	Min	Max	Unit	Sub-groups
RR	Ripple Rejection	$I_L = 125mA$ , $e_i = 1V_{RMS}$ , $f = 2.4KHz$ , $V_I = 10V$		62		dB	4, 5, 6

## LM140H-12 Electrical Characteristics

### DC Parameters

The following conditions apply, unless otherwise specified.

DC:  $V_I = 19V$ ,  $I_L = 350mA$

Symbol	Parameter	Conditions	Notes	Min	Max	Unit	Sub-groups
$V_O$	Output Voltage	$V_I = 35V$ , $I_L = 5mA$		11.4	12.6	V	1
				11.5	12.5	V	1
		$V_I = 15.5V$		11.4	12.6	V	1, 2, 3
		$V_I = 15.5V$ , $I_L = 5mA$		11.4	12.6	V	1, 2, 3
		$V_I = 27V$ , $I_L = 5mA$		11.4	12.6	V	1, 2, 3
$R_{Line}$	Line Regulation	$14.5V \leq V_I \leq 30V$ , $I_L = 200mA$		-60	60	mV	1
		$15.0V \leq V_I \leq 30V$ , $I_L = 200mA$		-120	120	mV	2, 3
		$16V \leq V_I \leq 25V$ , $I_L = 200mA$		-30	30	mV	1
				-60	60	mV	2, 3
$R_{Load}$	Load Regulation	$5mA \leq I_L \leq 500mA$		-120	120	mV	1
				-240	240	mV	2, 3
		$5mA \leq I_L \leq 200mA$		-60	60	mV	1
				-120	120	mV	2, 3
$I_Q$	Quiescent Current				7.0	mA	1, 2, 3
$\Delta I_Q$	Quiescent Current Change	$14.5V \leq V_I \leq 30V$ , $I_L = 200mA$		-0.8	0.8	mA	1, 2, 3
		$5mA \leq I_L \leq 350mA$		-0.5	0.5	mA	1, 2, 3
$I_{Pk}$	Peak Current	$V_I - V_O = 7V$	(Note 4)	0.4	2.0	A	1, 2, 3
$V_{DO}$	Dropout Voltage		(Note 5)		2.5	V	1
$I_{OS}$	Short Circuit Current	$V_I = 35V$			1.0	A	1, 2, 3

### AC Parameters

Symbol	Parameter	Conditions	Notes	Min	Max	Unit	Sub-groups
RR	Ripple Rejection	$V_I = 17V$ , $I_L = 125mA$ , $e_i = 1V_{RMS}$ , $f = 2.4KHz$		55		dB	4, 5, 6

## LM140H–15 Electrical Characteristics

### DC Parameters

The following conditions apply, unless otherwise specified.

DC:  $V_I = 23V$ ,  $I_L = 350mA$

Symbol	Parameter	Conditions	Notes	Min	Max	Unit	Sub-groups
$V_O$	Output Voltage	$V_I = 35V$ , $I_L = 5mA$		14.25	15.75	V	1
				14.40	15.60	V	1
		$V_I = 18.5V$		14.25	15.75	V	1, 2, 3
		$V_I = 18.5V$ , $I_L = 5mA$		14.25	15.75	V	1, 2, 3
		$V_I = 30V$ , $I_L = 5mA$		14.25	15.75	V	1, 2, 3
		$V_I = 30V$		14.25	15.75	V	1, 2, 3
$R_{Line}$	Line Regulation	$17.5V \leq V_I \leq 30V$ , $I_L = 200mA$		-60	60	mV	1
		$18.5V \leq V_I \leq 30V$ , $I_L = 200mA$		-120	120	mV	2, 3
		$20V \leq V_I \leq 30V$ , $I_L = 200mA$		-30	30	mV	1
				-60	60	mV	2, 3
$R_{Load}$	Load Regulation	$5mA \leq I_L \leq 500mA$		-150	150	mV	1
				-300	300	mV	2, 3
		$5mA \leq I_L \leq 200mA$		-75	75	mV	1
				-150	150	mV	2, 3
$I_Q$	Quiescent Current				7.0	mA	1, 2, 3
$\Delta I_Q$	Quiescent Current Change	$17.5V \leq V_I \leq 30V$ , $I_L = 200mA$		-0.8	0.8	mA	1, 2, 3
		$5mA \leq I_L \leq 350mA$		-0.5	0.5	mA	1, 2, 3
$I_{Pk}$	Peak Current	$V_I - V_O = 7V$	(Note 4)	0.4	2.0	A	1, 2, 3
$V_{DO}$	Dropout Voltage		(Note 5)		2.5	V	1
$I_{OS}$	Short Circuit Current	$V_I = 35V$			1.0	A	1, 2, 3

### AC Parameters

The following conditions apply, unless otherwise specified.

AC:  $V_I = 23V$ ,  $I_L = 350mA$

Symbol	Parameter	Conditions	Notes	Min	Max	Unit	Sub-groups
RR	Ripple Rejection	$V_I = 20V$ , $I_L = 125mA$ , $e_i = 1V_{RMS}$ , $f = 2.4KHz$		54		dB	4, 5, 6

## LM140K–5.0 Electrical Characteristics

### DC Parameters

The following conditions apply, unless otherwise specified.

DC:  $V_I = 10V$ ,  $I_L = 5mA$

Symbol	Parameter	Conditions	Notes	Min	Max	Unit	Sub-groups
$I_Q$	Quiescent Current	$I_L = 1A$			6.0	mA	1
					7.0	mA	2, 3
$\Delta Q$	Quiescent Current Change	$I_L = 1A$ , $8V \leq V_I \leq 20mA$		-0.8	0.8	mA	1
		$I_L \leq 500mA$ , $8V \leq V_I \leq 25V$		-0.8	0.8	mA	1, 2, 3
		$5mA \leq I_L \leq 1.0A$		-0.5	0.5	mA	1, 2, 3
$V_O$	Output Voltage			4.80	5.20	V	1
		$V_I = 8V$		4.75	5.25	V	1, 2, 3
		$V_I = 8V$ , $I_L = 1A$		4.75	5.25	V	1, 2, 3
		$V_I = 20V$		4.75	5.25	V	1, 2, 3
		$V_I = 20V$ , $I_L = 1A$		4.75	5.25	V	1, 2, 3
$R_{Line}$	Line Regulation	$I_L = 500mA$ , $7V \leq V_I \leq 25V$		-50	50	mV	1, 2, 3
		$I_L = 1A$ , $7.3V \leq V_I \leq 20V$		-50	50	mV	1
		$I_L = 1A$ , $8.0V \leq V_I \leq 20V$		-50	50	mV	2, 3
		$I_L = 1A$ , $8V \leq V_I \leq 12V$		-25	25	mV	1, 2, 3
$R_{Load}$	Load Regulation	$5mA \leq I_L \leq 1.5A$		-50	50	mV	1
		$5mA \leq I_L \leq 1.0A$		-50	50	mV	2, 3
		$250mA \leq I_L \leq 750mA$		-25	25	mV	1
$I_{OS}$	Current Limit			-4.0	-0.02	A	1
		$V_I = 35V$		-2.0	-0.02	A	1

### AC Parameters

The following conditions apply, unless otherwise specified.

AC:  $V_I = 10V$ ,  $I_L = 5mA$

Symbol	Parameter	Conditions	Notes	Min	Max	Unit	Sub-groups
RR	Ripple Rejection	$f = 120Hz$ , $I_L = 350mA$ , $e_i = 1V_{RMS}$		68		dB	4

## LM140K–12 Electrical Characteristics

### DC Parameters

The following conditions apply, unless otherwise specified.

DC:  $V_I = 19V$ ,  $I_L = 5mA$

Symbol	Parameter	Conditions	Notes	Min	Max	Unit	Sub-groups
$I_Q$	Quiescent Current	$I_L = 1A$			6.0	mA	1
					7.0	mA	2, 3
$\Delta I_Q$	Quiescent Current Change	$I_L = 1A$ , $15.5V \leq V_I \leq 27V$		-0.8	0.8	mA	1
		$I_L = 500mA$ , $15V \leq V_I \leq 30V$		-0.8	0.8	mA	1, 2, 3
		$5mA \leq I_L \leq 1A$		-0.5	0.5	mA	1, 2, 3
$V_O$	Output Voltage			11.5	12.5	V	1
		$V_I = 15.5V$		11.4	12.6	V	1, 2, 3
		$V_I = 15.5V$ , $I_L = 1A$		11.4	12.6	V	1, 2, 3
		$V_I = 27V$		11.4	12.6	V	1, 2, 3
		$V_I = 27V$ , $I_L = 1A$		11.4	12.6	V	1, 2, 3
$R_{Line}$	Line Regulation	$I_L = 500mA$ , $14.5V \leq V_I \leq 25V$		-120	120	mV	1, 2, 3
		$I_L = 1A$ , $14.6V \leq V_I \leq 27V$		-120	120	mV	1
		$I_L = 1A$ , $15.0V \leq V_I \leq 27V$		-120	120	mV	2, 3
		$I_L = 1A$ , $16V \leq V_I \leq 22V$		-60	60	mV	1, 2, 3
$R_{Load}$	Load Regulation	$5mA \leq I_L \leq 1.5A$		-120	120	mV	1
		$5mA \leq I_L \leq 1.0A$		-120	120	mV	2, 3
		$250mA \leq I_L \leq 750mA$		-60	60	mV	1
$I_{OS}$	Current Limit	$V_I = 17V$		-3.5	-0.02	A	1
		$V_I = 35V$		-2.0	-0.02	A	1

### AC Parameters

The following conditions apply, unless otherwise specified.

AC:  $V_I = 19V$ ,  $I_L = 5mA$

Symbol	Parameter	Conditions	Notes	Min	Max	Unit	Sub-groups
RR	Ripple Rejection	$f = 120Hz$ , $I_L = 350mA$ , $e_i = 1V_{RMS}$		61		dB	4

## LM140K–15 Electrical Characteristics

### DC Parameters

The following conditions apply, unless otherwise specified.

DC:  $V_I = 23V$ ,  $I_L = 5mA$

Symbol	Parameter	Conditions	Notes	Min	Max	Unit	Sub-groups
$I_Q$	Quiescent Current	$I_L = 1A$			6.0	mA	1
					7.0	mA	2, 3
$\Delta I_Q$	Quiescent Current Change	$I_L = 1A$ , $18.5V \leq V_I \leq 30V$		-0.8	0.8	mA	1
		$I_L = 500mA$ , $18.5V \leq V_I \leq 30V$		-0.8	0.8	mA	2, 3
		$5mA \leq I_L \leq 1A$		-0.5	0.5	mA	1, 2, 3
$V_O$	Output Voltage			14.4	15.6	V	1
		$V_I = 18.5V$		14.25	15.75	V	1, 2, 3
		$V_I = 18.5V$ , $I_L = 1A$		14.25	15.75	V	1, 2, 3
		$V_I = 30V$		14.25	15.75	V	1, 2, 3
		$V_I = 30V$ , $I_L = 1A$		14.25	15.75	V	1, 2, 3
$R_{Line}$	Line Regulation	$I_L = 500mA$ , $17.5V \leq V_I \leq 30V$		-150	150	mV	1
		$I_L = 500mA$ , $18.5V \leq V_I \leq 30V$		-150	150	mV	2, 3
		$I_L = 1A$ , $17.7V \leq V_I \leq 30V$		-75	75	mV	1
		$I_L = 1A$ , $20V \leq V_I \leq 26V$		-75	75	mV	1, 2, 3
$R_{Load}$	Load Regulation	$5mA \leq I_L \leq 1.5A$		-150	150	mV	1
		$5mA \leq I_L \leq 1.0A$		-150	150	mV	2, 3
		$250mA \leq I_L \leq 750mA$		-75	75	mV	1
$I_{OS}$	Current Limit	$V_I = 20V$		-3.5	-0.02	A	1
		$V_I = 35V$		-2.0	-0.02	A	1

### AC Parameters

The following conditions apply, unless otherwise specified.

AC:  $V_I = 23V$ ,  $I_L = 5mA$

Symbol	Parameter	Conditions	Notes	Min	Max	Unit	Sub-groups
RR	Ripple Rejection	$f = 120Hz$ , $I_L = 350mA$ , $e_i = 1V_{RMS}$		60		dB	4

**Note 1:** Absolute Maximum Ratings indicate limits beyond which damage to the device may occur. Operating Ratings indicate conditions for which the device is functional, but do not guarantee specific performance limits. For guaranteed specifications and test conditions, see the Electrical Characteristics. The guaranteed specifications apply only for the test conditions listed. Some performance characteristics may degrade when the device is not operated under the listed test conditions.

**Note 2:** The maximum power dissipation must be derated at elevated temperatures and is dictated by  $T_{Jmax}$  (maximum junction temperature),  $\theta_{JA}$  (package junction to ambient thermal resistance), and  $T_A$  (ambient temperature). The maximum allowable power dissipation at any temperature is  $P_{Dmax} = (T_{Jmax} - T_A) / \theta_{JA}$  or the number given in the Absolute Maximum Ratings, whichever is lower.

**Note 3:** Human body model, 100pF discharged through 1.5K $\Omega$

**Note 4:**  $V_O$  is set to 90%  $V_{Ref}$

**Note 5:**  $V_{DO} = V_I - V_O$  when  $V_O$  is 95% of  $V_{Ref}$ .



## Revision History Section

Released	Revision	Section	Originator	Changes
02/21/06	A	New Release, Corporate format	L. Lytle	6 MDS data sheets converted into one Corp. data sheet format. The drift tables were eliminated from the 883 section since it did not apply. MDS data sheets MNLM140-05H Rev 0B0, MNLM140-05-K Rev. 0C0, MNLM140-12H Rev 0A0, MNLM140-12K Rev 0B0, MNLM140-15H Rev 0A0, and MNLM140-15K Rev 0B0 will be archived.

**Physical Dimensions** inches (millimeters) unless otherwise noted

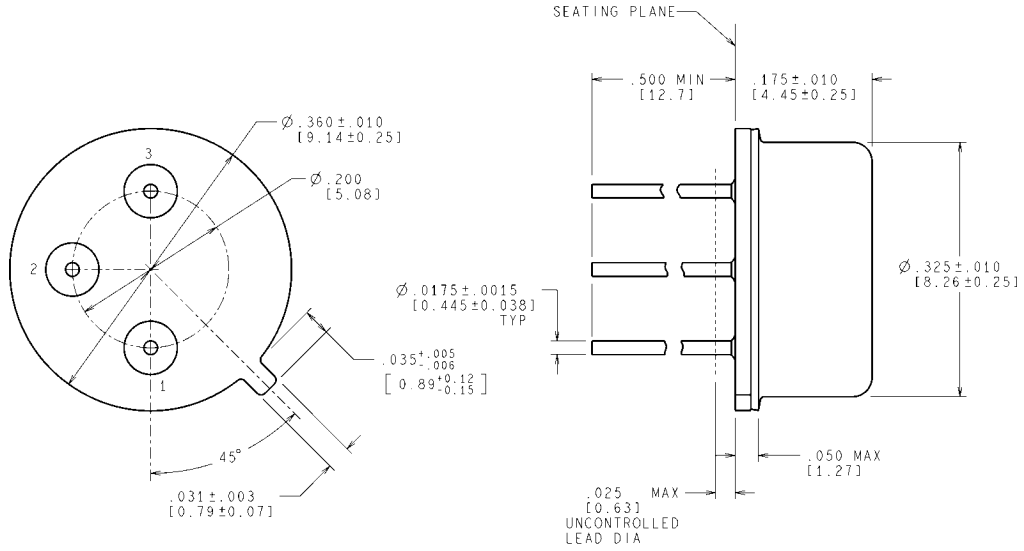

CONTROLLING DIMENSION IS INCH  
VALUES IN [ ] ARE MILLIMETERS

MIL-PRF-38535  
CONFIGURATION CONTROL

H03A (Rev D)

**Metal Can TO-39 (H)  
NS Package Number H03A**

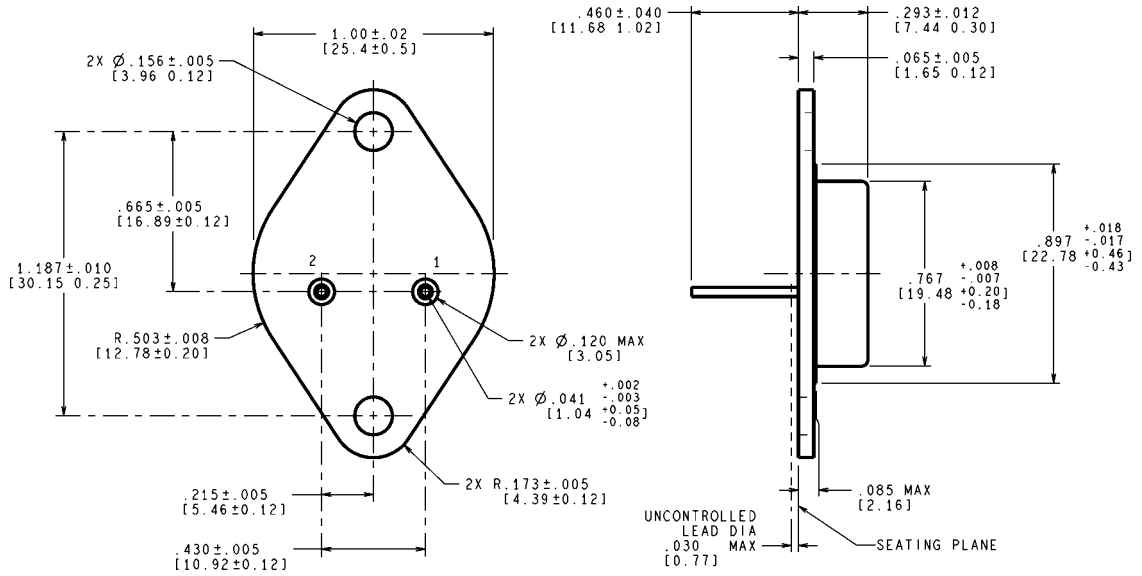

CONTROLLING DIMENSION IS INCH  
VALUES IN [ ] ARE MILLIMETERS

MIL-PRF-38535  
CONFIGURATION CONTROL

K02C (Rev E)

**Steel Metal Can Package (K)  
NS Package Number K02C**

# Notes

LM140QML

## Notes

For more National Semiconductor product information and proven design tools, visit the following Web sites at:

Products		Design Support	
Amplifiers	<a href="http://www.national.com/amplifiers">www.national.com/amplifiers</a>	WEBENCH	<a href="http://www.national.com/webench">www.national.com/webench</a>
Audio	<a href="http://www.national.com/audio">www.national.com/audio</a>	Analog University	<a href="http://www.national.com/AU">www.national.com/AU</a>
Clock Conditioners	<a href="http://www.national.com/timing">www.national.com/timing</a>	App Notes	<a href="http://www.national.com/appnotes">www.national.com/appnotes</a>
Data Converters	<a href="http://www.national.com/adc">www.national.com/adc</a>	Distributors	<a href="http://www.national.com/contacts">www.national.com/contacts</a>
Displays	<a href="http://www.national.com/displays">www.national.com/displays</a>	Green Compliance	<a href="http://www.national.com/quality/green">www.national.com/quality/green</a>
Ethernet	<a href="http://www.national.com/ethernet">www.national.com/ethernet</a>	Packaging	<a href="http://www.national.com/packaging">www.national.com/packaging</a>
Interface	<a href="http://www.national.com/interface">www.national.com/interface</a>	Quality and Reliability	<a href="http://www.national.com/quality">www.national.com/quality</a>
LVDS	<a href="http://www.national.com/lvds">www.national.com/lvds</a>	Reference Designs	<a href="http://www.national.com/refdesigns">www.national.com/refdesigns</a>
Power Management	<a href="http://www.national.com/power">www.national.com/power</a>	Feedback	<a href="http://www.national.com/feedback">www.national.com/feedback</a>
Switching Regulators	<a href="http://www.national.com/switchers">www.national.com/switchers</a>		
LDOs	<a href="http://www.national.com/lido">www.national.com/lido</a>		
LED Lighting	<a href="http://www.national.com/led">www.national.com/led</a>		
PowerWise	<a href="http://www.national.com/powerwise">www.national.com/powerwise</a>		
Serial Digital Interface (SDI)	<a href="http://www.national.com/sdi">www.national.com/sdi</a>		
Temperature Sensors	<a href="http://www.national.com/tempsensors">www.national.com/tempsensors</a>		
Wireless (PLL/VCO)	<a href="http://www.national.com/wireless">www.national.com/wireless</a>		

THE CONTENTS OF THIS DOCUMENT ARE PROVIDED IN CONNECTION WITH NATIONAL SEMICONDUCTOR CORPORATION ("NATIONAL") PRODUCTS. NATIONAL MAKES NO REPRESENTATIONS OR WARRANTIES WITH RESPECT TO THE ACCURACY OR COMPLETENESS OF THE CONTENTS OF THIS PUBLICATION AND RESERVES THE RIGHT TO MAKE CHANGES TO SPECIFICATIONS AND PRODUCT DESCRIPTIONS AT ANY TIME WITHOUT NOTICE. NO LICENSE, WHETHER EXPRESS, IMPLIED, ARISING BY ESTOPPEL OR OTHERWISE, TO ANY INTELLECTUAL PROPERTY RIGHTS IS GRANTED BY THIS DOCUMENT.

TESTING AND OTHER QUALITY CONTROLS ARE USED TO THE EXTENT NATIONAL DEEMS NECESSARY TO SUPPORT NATIONAL'S PRODUCT WARRANTY. EXCEPT WHERE MANDATED BY GOVERNMENT REQUIREMENTS, TESTING OF ALL PARAMETERS OF EACH PRODUCT IS NOT NECESSARILY PERFORMED. NATIONAL ASSUMES NO LIABILITY FOR APPLICATIONS ASSISTANCE OR BUYER PRODUCT DESIGN. BUYERS ARE RESPONSIBLE FOR THEIR PRODUCTS AND APPLICATIONS USING NATIONAL COMPONENTS. PRIOR TO USING OR DISTRIBUTING ANY PRODUCTS THAT INCLUDE NATIONAL COMPONENTS, BUYERS SHOULD PROVIDE ADEQUATE DESIGN, TESTING AND OPERATING SAFEGUARDS.

EXCEPT AS PROVIDED IN NATIONAL'S TERMS AND CONDITIONS OF SALE FOR SUCH PRODUCTS, NATIONAL ASSUMES NO LIABILITY WHATSOEVER, AND NATIONAL DISCLAIMS ANY EXPRESS OR IMPLIED WARRANTY RELATING TO THE SALE AND/OR USE OF NATIONAL PRODUCTS INCLUDING LIABILITY OR WARRANTIES RELATING TO FITNESS FOR A PARTICULAR PURPOSE, MERCHANTABILITY, OR INFRINGEMENT OF ANY PATENT, COPYRIGHT OR OTHER INTELLECTUAL PROPERTY RIGHT.

### LIFE SUPPORT POLICY

**NATIONAL'S PRODUCTS ARE NOT AUTHORIZED FOR USE AS CRITICAL COMPONENTS IN LIFE SUPPORT DEVICES OR SYSTEMS WITHOUT THE EXPRESS PRIOR WRITTEN APPROVAL OF THE CHIEF EXECUTIVE OFFICER AND GENERAL COUNSEL OF NATIONAL SEMICONDUCTOR CORPORATION.** As used herein:

Life support devices or systems are devices which (a) are intended for surgical implant into the body, or (b) support or sustain life and whose failure to perform when properly used in accordance with instructions for use provided in the labeling can be reasonably expected to result in a significant injury to the user. A critical component is any component in a life support device or system whose failure to perform can be reasonably expected to cause the failure of the life support device or system or to affect its safety or effectiveness.

National Semiconductor and the National Semiconductor logo are registered trademarks of National Semiconductor Corporation. All other brand or product names may be trademarks or registered trademarks of their respective holders.

Copyright© 2008 National Semiconductor Corporation

For the most current product information visit us at [www.national.com](http://www.national.com)



**National Semiconductor  
Americas Technical  
Support Center**  
Email:  
[new.feedback@nsc.com](mailto:new.feedback@nsc.com)  
Tel: 1-800-272-9959

**National Semiconductor Europe  
Technical Support Center**  
Email: [europe.support@nsc.com](mailto:europe.support@nsc.com)  
German Tel: +49 (0) 180 5010 771  
English Tel: +44 (0) 870 850 4288

**National Semiconductor Asia  
Pacific Technical Support Center**  
Email: [ap.support@nsc.com](mailto:ap.support@nsc.com)

**National Semiconductor Japan  
Technical Support Center**  
Email: [jpn.feedback@nsc.com](mailto:jpn.feedback@nsc.com)