

HE 8 / 127 Series

Connectors for PCB

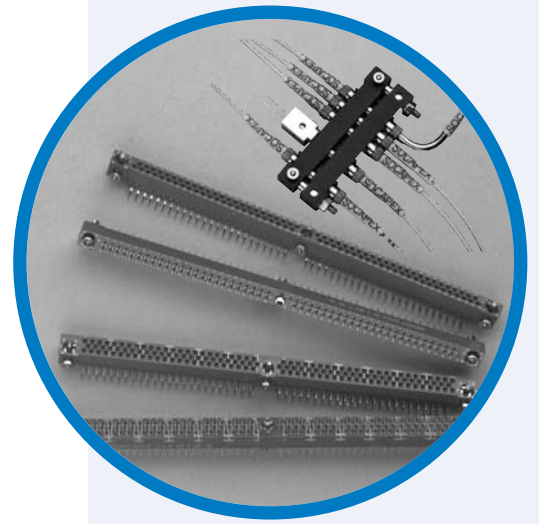

MAIN CHARACTERISTICS

Main features

The 127 series circuit board connectors are available in 3 different versions:

- **HE 801 / 127:** From 17 to 144 signal contacts, on 2 or 3 rows
Pin contacts with round sections
- **HE 804 / 127:** From 17 to 144 signal contacts, on 2 or 3 rows
Pin contacts with rectangular sections
- **HE 807 / 127H:** From 5 to 84 signal contacts and 3 to 10 size 16 cavities for power, coaxial contacts or optical termini
Pin contacts with round sections

Version	Insert height (mm)	Pin signal contacts	
		Shape	Section (mm ²)
HE 801	7.9	round, stamped	0.28
HE 804	6.9	rectangular, cut-out	0.48
HE 807	7.9	round, stamped	0.28

- Gold plating in accordance with NFC 93480: mini 0.8 µm Au
- Flexibility: 16 types of contacts, 25 types of fittings and 29 insert versions
- Crimp pin and socket contacts
- Repairability: possibility to change the contacts one by one
- Density: up to 144 contacts within 150 mm long inserts

Technical characteristics	
Temperature range	- 55°C / + 125°C (during 56 days)
Durability: - HE 801 & HE 804 - HE 807	500 cycles 250 cycles
Insulation resistance	≥ 5000 MΩ
Salt spray	96 hours
Vibrations	2000/10 g
Electrical discontinuities	≤ 1µs
Shocks: - HE 801 & HE 804 - HE 807	100 g 50 g
Rating voltage at 50 Hz	250 Vrms
Test voltage at sea level	1000 Vrms
Test current	see curve
Contact resistance	≤ 12 mΩ
Capacitance between contacts	≤ 5 pF
Mating/unmating force per contacts:	
- HE 801	0.14 N ≤ F ≤ 0.90 N
- HE 804	0.14 N ≤ F ≤ 1.60 N 0.14 N ≤ F ≤ 0.90 N (144 contacts)
- HE 807	0.14 N ≤ F ≤ 1.60 N 0.14 N ≤ F ≤ 0.90 N (84 + 10 contacts) 1 N ≤ F ≤ 15 N (coaxial contacts)
Contact retention in the insert:	
- HE 801	20 N for W contact
- HE 804 & HE 807	20 N for S, W and Z contacts
Torque values:	
- nut for Ø 2.5 mm screw, brass	0.25 mN
- nut for Ø 1.6 mm screw, brass	0.15 mN

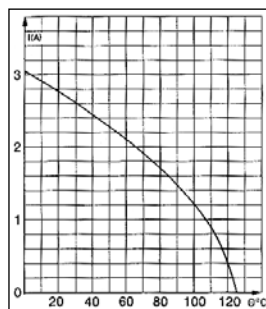

DESCRIPTION

The 127 series circuit board connectors are in accordance with several standards: NFC UTE 93424 (HE801, HE804 and HE807), BS9525 (-N0001, -F0006 and -F0007), MIL-C-55302 (140 to 155) and CEI130-16.

The 127 series use a 1.27 mm staggered pitch with 2.54 mm between the rows.

Different versions are available, from 17 to 144 contacts, with different terminations: straight, right angled, crimp, solder, SMT and wire-wrap. Mixed layout styles exist, providing the addition of 3 to 10 cavities accepting either power or coaxial contacts as well as optical termini.

Low profile rectangular PCB connectors

APPLICATIONS

- Ground military and aircraft applications
- Telecom applications
- Avionics applications

The 127 series connectors are used among others in the Mirage, Rafale and Leclerc programs

HE8 / 127

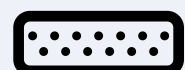

Amphenol

Arrangements

127 H – HE 807 Series				Dimensions (mm)		127 – HE 801 / HE 804 Series	
Mating side view of plug	Contacts		A	B	□	●	
	□	⊠					
	5	3	37.7	30.5	17	●	
	17	3	52.9	45.7	29	●	
	5	6					
	0	7					
	0	8	58	50,8	33	●	
	29	3	68.2	60.9	41	●	
	17	6	83.4	76.2	53	●	
	41	3					
	29	6					
	53	3	98.7	91.4	65	●	
	41	6	113.9	106.7	72	●	
	60	3					
	48	6					
	72	3	129.1	121.9	84	●	
	60	6	144.4	137.1	96	●	
	84	3					
	72	6					
	56	10					
2 rows: e = 6.3 mm	3 rows: 80 cts: e = 8.94 mm max 144 cts: e = 8.55 mm max		83.4	76.2	80	●	
			144.4	137.1	144	●	

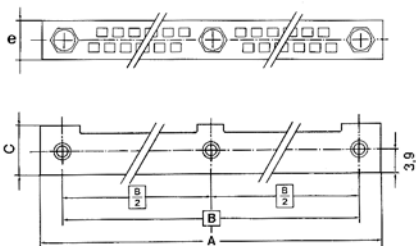

C = 6.8 mm (HE 804) C = 7.8 mm (HE 801-807)

- signal contacts
- ⊠ special contacts
- ▲ asymmetrical arrangements
- crimp contacts possibility

Contacts & fittings

Type	Socket contacts	Fittings compatible with socket contacts			Fittings (HE standard)		Fittings compatible with pin contacts			Pin contacts	Type	Installation
		127 2 rows	127 T 3 rows	127 H	801 807	804	127 2 rows	127 T 3 rows	127 H			
YC		A	A	A	101	101	J		A		YC	For installation instructions, please refer to pages 9 to 11
YL*		D	D	D	103	103	S		D		YL*	
T		AS	AS	AS	124	124	JS		AS			
		KE		KE	208	209	AE		KE			
		KED		KED	224	223	AED		KED			
		KET	PA	KET	425	425	AET		KET			
		PA	PA	PA	102	102	PC		PA			
U		H				107					U	
		N			115	106	N					
		NF			116	108	NF					
		NS			126	126	NS					
		V			114	104	V					
YD		L				228					Y	
Y				P	226							
		K		K	212	201	A	A	P			
		P			203	203	B	B	K			
W3		KD		KD	221	221	AD	AD	KD		W3	
		KY		KT	422	422	AT	AT	KT			
		E		E	117	110	R	R	E			
Z		EF		EF	119	112	RF	RF	E		ZC	
		ES		ES	125	125	RS	RS	ES			
		ET		ET	327	327	RT	RT	ET			
		T		T	118	11	T	D	T			
X1		S		S	219	220	D	D	S		X	
		SC		IE	213	206	DC					

→ Contact removal direction











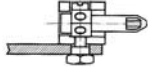
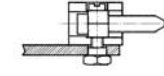
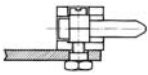
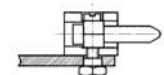
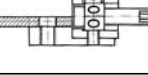
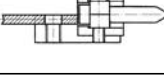
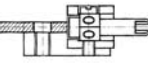

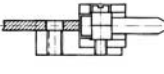
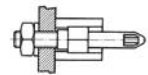
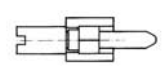
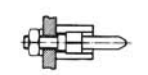
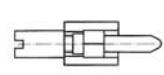

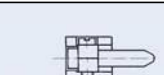
* X and XL connectors + HE8C101, 102, 103 or 124 fixing accessories + longer screw (P/N 44322) for 3.2 mm PCB

Tooling



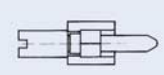

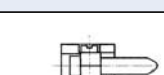
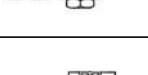

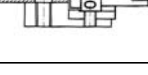
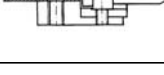



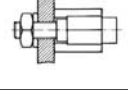
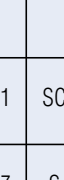
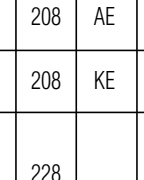

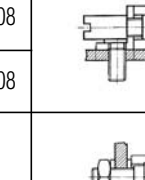

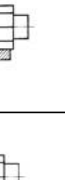
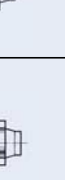
REMOVAL TOOLS								
Pin contacts	Removal direction	Tool	Socket contacts	Removal direction	Tool	Socket contacts	Removal direction	Tool
ZC-X-YC-YL	rear	1272	YC-U-Z (HE801-804)	rear	1271	W3 Y-YD	front	20973 20143
Y-W3-U	front	24098	YC-U-Z (HE807)	rear	24099	HE807 particular contacts	rear	23550

CRIMPING TOOLS						
Pin contacts	AWG	Tool	Socket	AWG	Tool	Turret
X	26 to 22	HE 8 20 051*	X1	26 to 22	809801 (M22520/2-01)	127.800 030

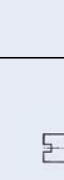
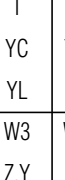

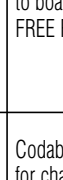
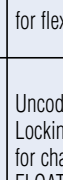
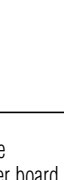

* No additional turret

HE	Fittings				◆ Recommended	HE8C P/N	Central fittings	Contacts		Description
	for contacts socket		pin					S	P	
	127	HE8C	127	HE8C						
804	A	101	J	101	◆ 	102		T	Codable. Unlockable Daughter board FREE PLUG	
801	A	101	J	101				YC		YC
807	A	101	A	101				YL		YL
804	PA	102	PC	102	◆ 	102		T	Uncodable. Unlockable Daughter or extensionboard FREE PLUG	
801	PA	102	PC	102				YC		YC
807	PA	102	PA	102				YL		YL
804	H	107			◆ 	105		U	Codable. Unlockable. Surface mount daughter board offset from centerline, FREE PLUG	
804	N	106	N	106	◆ 	104		U	Codable. Unlockable. Surface mount daughter board aligned with centerline, FREE PLUG	
801	N	115	N	115		114				
804	V	104	V	104	◆ 	104		U	Codable. Unlockable Daughter board aligned with centerline, FREE PLUG	
801	V	114	V	114		114				
804	E	110	R	110	◆ 	113		W3	Codable. Unlockable For chassis or mother board (board/board, board/chassis)	
801	E	117	R	117		129		Z,Y		ZC
807	E	117	E	117		129		YD,X1		Y,X
804	T	111	T	111	◆ 	113		W3	Uncodable Unlockable	
801	T	118	T	118		129		Z,Y		ZC
807	T	118	T	118		129		YD,X1		Y,X
804	D	103	S	103	◆ 	102		T	Uncodable Lockable on receptacle side Daughter board FREE PLUG	
801	D	103	S	103		102		YC		YC
807	D	103	D	103		102		YL		YL
804	NF	108	NF	108	◆ 	104		U	Lockable on receptacle side Surface mount daughter board aligned with centerline	
801	NF	116	NF	11		114				
804	EF	112	RF	112	◆ 	113		W3	Uncodable Lockable on receptacle side For chassis or mother board	
801	EF	119	RF	119		129		Z,Y		ZC
807	EF	119	EF	119		129		YD,X1		Y,X
804	AS	124	JS	124	◆ 	102		T	Codable Lockable on receptacle side Daughter board FREE PLUG	
801	AS	124	JS	124		102		YC		YC
807	AS	124	AS	124		102		YL		YL
804	NS	126	NS	126	◆ 	104		U	Codable. Lockable on receptacle side. Surface mount daughter board aligned with centerline	
801	NS		NS			114				
804	ES	125	RS	125	◆ 	113		W3	Codable Lockable on receptacle side For chassis or mother board	
801	ES	125	RS	125		129		Z,Y		ZC
807	ES	125	ES	125		129		YD,X1		Y,X
804	ET	327	RT	327	◆ 	313		W3	Codable Quarter turn lockable Cable/card or cable/chassis	
801	ET	327	RT	327		329		Z		ZC
807	ET	327	ET	327		329		X1		X

FOR A CONNECTOR'S MATING PAIR Receptacles – female fittings

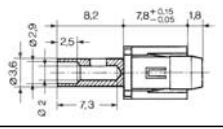
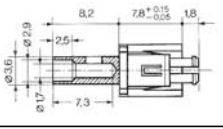
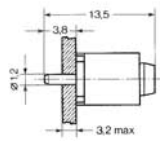
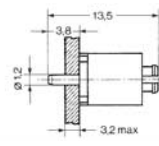
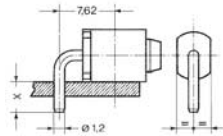
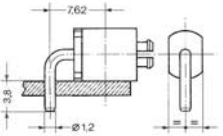
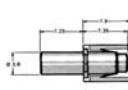
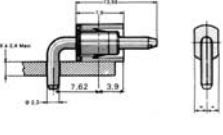
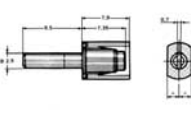
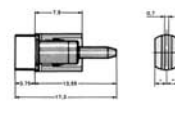
HE	Fittings				HE8C P/N	Central fittings	Contacts		Description	
	for contacts socket		pin				◆ Recommended	S		P
	127	HE8C	127	HE8C						
804	K	201	A	201	◆ 		W3	W3	Codable. Unlockable For chassis or mother board FIXED RECEPTACLE	
801	K	212	A	212			Z,Y	ZC		
807	K	212	K	212			YD,X1	Y,X		
804	P	203	B	203	◆ 		W3	W3	Codable. Unlockable For chassis FLOATING RECEPTACLE	
801	P	203	B	203			Z,Y	ZC		
807	P	226	P	226			YD	Y		
					229		X1	X		
804	KE	209	AE	209	◆ 		T	YC	Codable. Unlockable Daughter board or board to board mating FREE RECEPTACLE	
801	KE	208	AE	208			YL	YL		
807	KE	208	KE	208			T	U		
					208		YC	YC		
							YL	YL		
804	L	228			◆ 		W3	W3	Codable. Unlockable for chassis or mother board with insulating washer	
							Z,Y	ZC		
							YD,X1	Y,X		
804	S	220	D	220	◆ 		Z	ZC	Uncodable. Locking device-extractor for cables FREE RECEPTACLE	
801	S	219	D	219			W3	W3		
804	SC	207	DC	207			X1	X		
					202		Y	Y	for flex	
801	SC	213	DC	213	◆ 		W3	W3	Uncodable. Locking device-extractor for chassis FLOATING RECEPTACLE	
							Z,Y	ZC		
807	S	213	S	213			X1	Y,X		
804	KD	221	AD	221	◆ 		W3	W3	Codable. Locking by a central captive screw + screw-head retaining after locking, ensuring resistance to vibrations. FIXED RECEPTACLE	
801	KD	221	AD	221			X1	ZC		
807	KD	221	KD	221			Z,Y	Y,X		
804	KED	223	AED	223	◆ 		YC	YC	Codable. Locking by a central captive screw + screw-head retaining after locking, ensuring resistance to vibrations. For daughter board or board to board mating. FREE RECEPTACLE	
801	KED	224	AED	224			T	YL		
807	KED	224	KED	224			YC	YC		
					208		YL	YL		
804	KT	422	AT	422	◆ 		W3,Z	W3,X	Codable. Quarter turn locking For chassis or mother board FIXED RECEPTACLE	
801	KT	422	AT	422			X1	ZC		
807	KT	422	KT	422			YD	Y		
804	KET	425	AET	425	◆ 		T	YC	Codable. Quarter turn locking. For daughter board or board to board mating FREE RECEPTACLE	
801	KET	425	AET	425			YL	YL		
807	KET	425	KET	425						

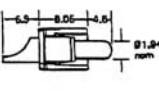
Power, coaxial and optical contacts for HE 807 / 127 H connectors

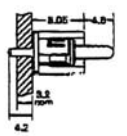
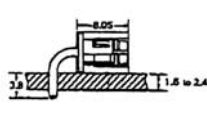
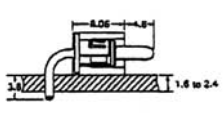
POWER CONTACTS					
Socket	P/N			P/N	Pin
Current rating 10 A					
	F121	<ul style="list-style-type: none"> - straight - for hard soldering on wire - suitable for wire diameter up to 2 mm 		M121	
	F141	<ul style="list-style-type: none"> - straight - for hard soldering on mother board - suitable for thickness board 3.2 mm max. 		M141	
	F132	<ul style="list-style-type: none"> - right angled - for hard soldering on daughter board - suitable for thickness board from 1.6 to 2.4 mm 		M132	
Current rating 20 A					
	F124	<ul style="list-style-type: none"> - straight - for hard soldering on wire - suitable for wire diameter up to 2 mm 	<ul style="list-style-type: none"> - right angled - for hard soldering on daughter board 	M134	
	F164	<ul style="list-style-type: none"> - straight - for mother board or bus bar 	<ul style="list-style-type: none"> - straight - for bus bar 	M164	
	FH1	<ul style="list-style-type: none"> - straight - for hard soldering on wire - suitable for wire diameter up to 1.83 mm 		MH1	
	FH2	<ul style="list-style-type: none"> - straight - for hard soldering on mother board - suitable for thickness board 3.2 mm max. 		MH2	
	FH3	<ul style="list-style-type: none"> - right angled - for hard soldering on daughter board - suitable for thickness board from 1.6 to 2.4 mm 		MH3	

Power, coaxial and optical contacts for HE 807 / 127 H connectors

OPTICAL TERMINI																	
<p>Straight pin</p>	<p>Straight socket</p>																
<p>Angled pin</p>																	
Dimensions in mm																	
<p>Technical characteristics</p> <table> <tbody> <tr> <td>Fiber type.....</td> <td>50/125, 62.5/125 and 100/140 μm</td> <td>Insertion loss.....</td> <td>0.5 dB (with 100/140 μm fibers)</td> </tr> <tr> <td>Cable type.....</td> <td>\varnothing 1.5 mm airborne tight jacket cable equipped with 100/140/500 μm fiber</td> <td>Durability.....</td> <td>250 cycles</td> </tr> <tr> <td>Material</td> <td>- metallic body - ceramic ferrule - ceramic alignment sleeve</td> <td>Temperature range</td> <td>- 55°C / + 125 °C</td> </tr> <tr> <td></td> <td></td> <td>Cable retention by crimping</td> <td>> 10 daN</td> </tr> </tbody> </table>		Fiber type.....	50/125, 62.5/125 and 100/140 μm	Insertion loss.....	0.5 dB (with 100/140 μm fibers)	Cable type.....	\varnothing 1.5 mm airborne tight jacket cable equipped with 100/140/500 μm fiber	Durability.....	250 cycles	Material	- metallic body - ceramic ferrule - ceramic alignment sleeve	Temperature range	- 55°C / + 125 °C			Cable retention by crimping	> 10 daN
Fiber type.....	50/125, 62.5/125 and 100/140 μm	Insertion loss.....	0.5 dB (with 100/140 μm fibers)														
Cable type.....	\varnothing 1.5 mm airborne tight jacket cable equipped with 100/140/500 μm fiber	Durability.....	250 cycles														
Material	- metallic body - ceramic ferrule - ceramic alignment sleeve	Temperature range	- 55°C / + 125 °C														
		Cable retention by crimping	> 10 daN														

How to order

Series (2 rows)	127	MD	16	C	A1	15	CO
Contact type							
MD: Straight pin							
MC: Angled pin							
FD: Straight socket							
Contact size							
Ceramic ferrule							
Cable type							
A1: 50/62.5/125/500 μm							
C1: 100/140 μm							
Cable code							
15: cable \varnothing 1.5 mm							
For other cables, please consult us							
Obligatory suffix							

For installation instructions, please consult us.

Panel and printed circuit board drilling for HE 801 – HE 804 / 127 connectors

Panel drilling

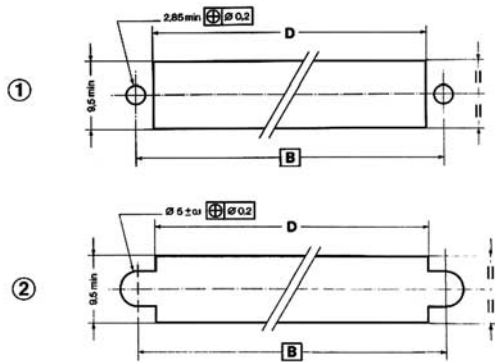

	Receptacles		Plugs	
	Fittings	Contacts	Fittings	Contacts
Fig. 1	A-AD-AT	Pin W3-ZC-X	R-RF-RS-T	Pin W3-ZC-X
	K-KD-KT-L	Socket W3-Z	E-EF-ES-T	Socket W3-Z
Fig. 2	B	Pin W3-ZC-X		
	P	Socket W3-Z		

Printed circuit board drilling

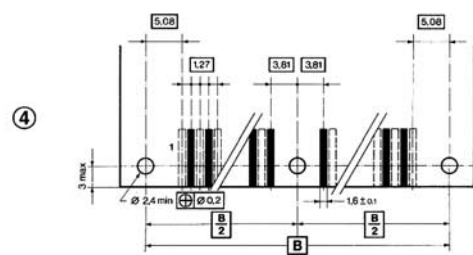
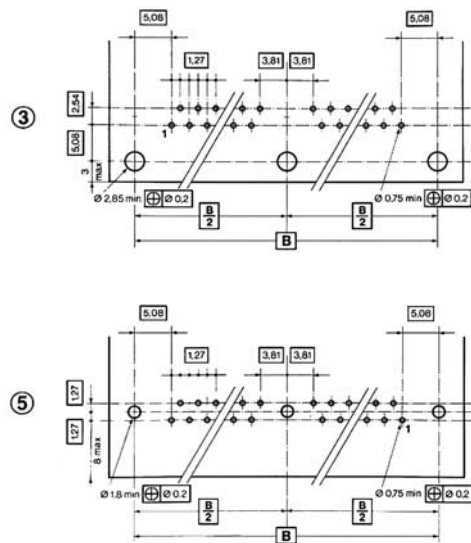

	Daughterboard drilling for:			
	Receptacles		Plugs	
	Fittings	Contacts	Fittings	Contacts
Fig. 3	KET AET	YC	A-D-AS-PA J-S-JS-PC	YC
Fig. 4			H-N-NF NS-V	U
Fig. 5	KE-KED AE-AED	YC		

Note:

The boards are illustrated from the connector side

The figures show the drilling of PC boards with connectors equipped with central guides (72, 84 and 96 contacts).

For smaller connectors (17, 29, 33, 41, 53 and 65 contacts), take no notice of the central drilling.

All contacts outputs are equidistant.

For daughterboards, the first contact's marking is indicated as reference only.

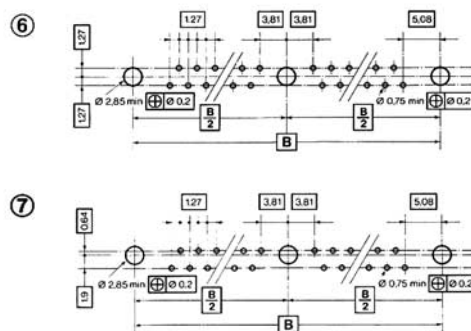

	Motherboard drilling for:			
	Receptacles		Plugs	
	Fittings	Contacts	Fittings	Contacts
Fig. 6	A-AD-AT	Y (pin)	R-RF-RS-T	Y (pin)
Fig. 7	K-L-KD-KT	YD (socket)	E-EF-ES-T	YD (socket)

Dimensions (mm) – Refer to fig. 1 to 7									
Number of contacts	17	29	33	41	53	65	72	84	96
Dimension B	30.48	45.72	50.80	60.96	76.20	91.44	106.68	121.92	137.16
Dimension D	25.90	41.10	46.20	56.40	71.60	86.90	102.10	117.30	132.60

Panel and printed circuit board drilling for HE 807 / 127 H connectors

Panel drilling

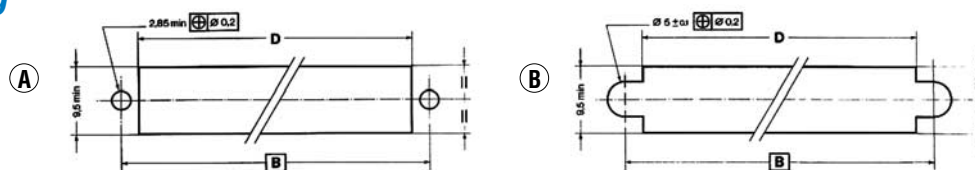

	Receptacles					Plugs				
	Fittings	Pin contacts signal	Pin contacts special	Socket contacts signal	Socket contacts special	Fittings	Pin contacts signal	Pin contacts special	Socket contacts signal	Socket contacts special
Fig. A	K KD KT	W3 ZC-X	Please refer to pages 6 to 8	W3 ZC-X1	Please refer to pages 6 to 8	E EF ES	W3 ZC-X	Please refer to pages 6 to 8	W3 ZC-X1	Please refer to pages 6 to 8
Fig. B	P	W3 ZC-X	Please refer to pages 6 to 8	W3 ZC-X1	Please refer to pages 6 to 8					

Printed circuit board drilling

Note: (referring to the following page)

The boards are illustrated from the connector side

The figures show the drilling of PC boards with connectors equipped with central guides (72, 84 and 96 contacts).

For smaller connectors (17, 29, 33, 41, 53 and 65 contacts), take no notice of the central drilling. All contacts outputs are equidistant.

The illustrated drilling corresponds to connectors fitted with 3 coaxial or power contacts at one extremity and signal contacts at the other one.

For daughterboards, the first contact's marking is indicated as reference only.

	Daughterboard drilling for:					
	Receptacles			Plugs		
	Fittings	Contacts signal	Contacts coaxial	Fittings	Contacts signal	Contacts coaxial
Fig. 1 on page 11	KET	YC	F032/M032	A-D AS-PA	YC	F032/M032
Fig. 2 on page 11	KE	YC	F032/M032			
Fig. 3 on page 11	IE	YC	F032/M032			
	Fittings	Contacts signal	Contacts power	Fittings	Contacts signal	Contacts power
Fig. 5 on page 11	KE	YC	FH3/MH3 F132/M132	A-D AS-PA	YC	FH3/MH3 F132/M132
Fig. 6 on page 11	IE	YC	FH3/MH3 F132/M132			
Fig. 7 on page 11	IE	YC	FH3/MH3 F132/M132			

	Motherboard drilling for:					
	Receptacles			Plugs		
	Fittings	Contacts signal	Contacts coaxial	Fittings	Contacts signal	Contacts coaxial
Fig. 4 on page 11	K KD KT	Y	F041/M041	A-D AS-PA	YC	F041/M041
	Fittings	Contacts signal	Contacts power	Fittings	Contacts signal	Contacts power
Fig. 8 on page 11	K KD KT	Y	FH2/MH2 F141/M141	A-D AS-PA	YC	FH2/MH2 F141/M141

Dimensions (mm) – Refer to fig. A and B and to fig. 1 to 8 on page 11								
Number of contacts	5 + 3	17 + 3 5 + 6 0 + 7 0 + 8	29 + 3 17 + 6	41 + 3 29 + 6	53 + 3 41 + 6	60 + 3 48 + 6	72 + 3 60 + 6	84 + 3 72 + 6 56 + 10
Dimension B	17	29	41	53	65	72	84	96
Dimension D	25.90	41.10	56.40	71.60	86.90	102.10	117.30	132.60

Printed circuit board drilling for HE 807 / 127 H connectors

Coaxial contacts

Power contacts

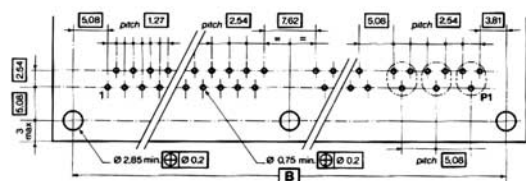

① Daughter board

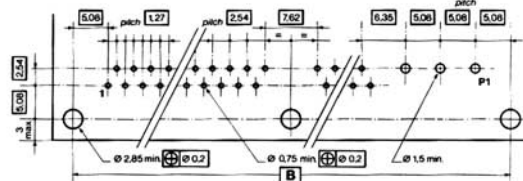

⑤ Daughter board

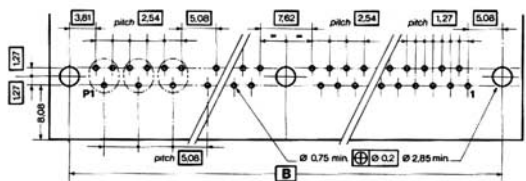

② Daughter board

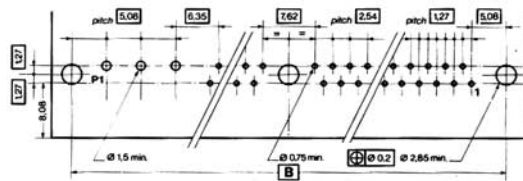

⑥ Daughter board

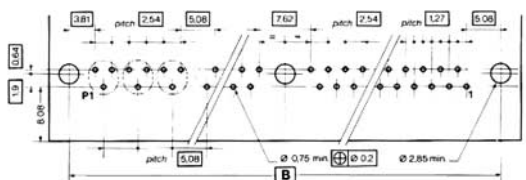

③ Daughter board

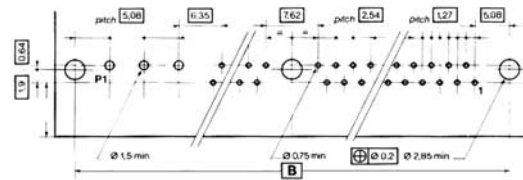

⑦ Daughter board

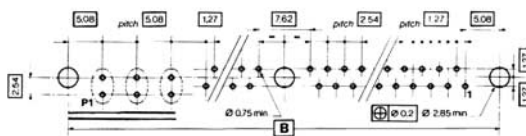

④ Mother board

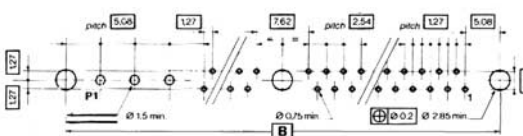

⑧ Mother board

PCB drilling for 0 + 7 and 0 + 8 insert arrangements

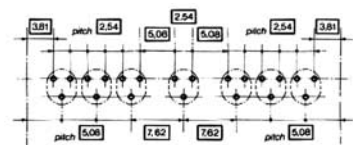

F032/M032 contacts

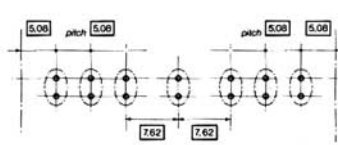

F041/M041 contacts

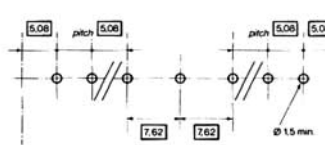

FH2/MH2 contacts
FH3/MH3 contacts
F132/M132 contacts
F141/M141 contacts

For the 0 + 8 insert arrangement, the PCB drilling is the same one as the drilling for the 3 first contacts of the 0 + 7 insert arrangement.

Hoods with locking rods for HE 804 plugs

Hoods are available for series HE 804 plugs. They are suitable for use with strand and ribbon cables, as well as flex circuits. They suit to plugs supplied without fittings. The fittings, derived from the standard ones, are delivered with the hoods and enable the polarisation.

These hoods are used with HE 804 plugs: - without fittings
 - fitted with 29, 41 or 65 pin or socket contacts
 - equipped with U, Z, ZC or X contacts

A hood is composed of the following parts (see fig. 1):

- 2 thermoplastic flanges (a)
- 2 locking rods (b)
- 1 inner cable clamp (c) for strand or flat cable depending of the type of hood
- 2 fittings (d) to ensure the guiding and the polarisation
- the assembly screws

The working temperature is - 40°C to + 125°C.

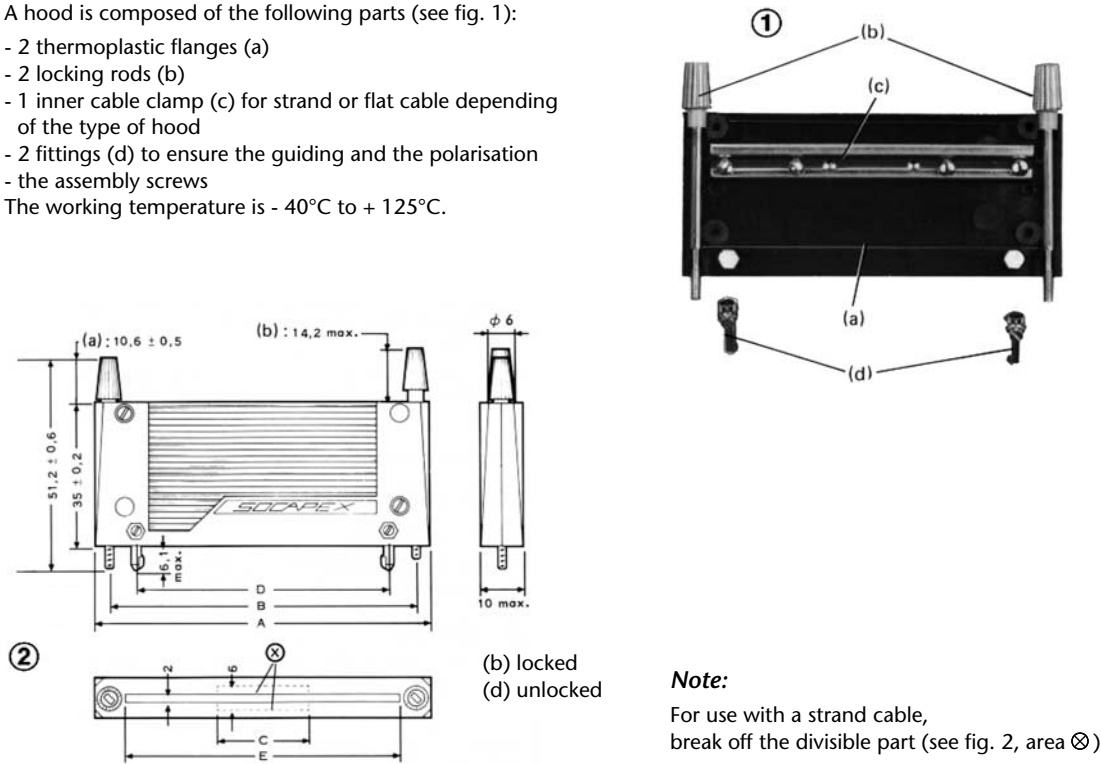

Note:
 For use with a strand cable,
 break off the divisible part (see fig. 2, area ⊗)

Number of contacts	Dimensions (mm) – see fig. 2				
	A ± 0.3	B	C	D	E
29	65.30	59.32	18.00	47.72	45.80
41	80.50	74.56	22.00	60.96	61.00
65	111.00	105.04	48.00	91.44	91.50

How to order

Series	127	29	TF	1
Number of contacts 29, 41, 65				
Type of hood TF: hood for female plug TM: hood for male plug				
Type of cable clamp 1: for flat cable or flex circuit 2: for strand cable				

Plugs equipped with hoods mate with receptacles equipped with screwlock sockets (refer to page 13).

Locking systems for HE 804 plugs

These locking systems are used with HE 804 plugs: - without fittings
- fitted with 17, 29, 33, 41, 53 or 65 pin or socket contacts
- equipped with U, Z, ZC or X contacts

A set of locking systems is composed of the following parts (see fig. 1):

- 2 thermoplastic extremity blocks (a) equipped with 2 captive locking rods (b)
- 2 fittings (d) to ensure the guiding and the polarisation

The working temperature is - 40°C to + 125°C.

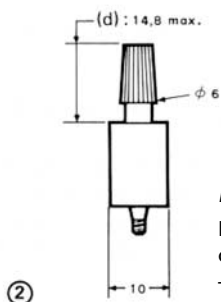
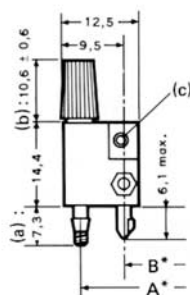

(b) locked
(d) unlocked

Note:

For use with ribbon cable or flex circuit, 2 epoxy glass strain relief stripes can be supplied.

They are fastened to point (c) with PARKER CMB n°2 screws (4.8 mm long).

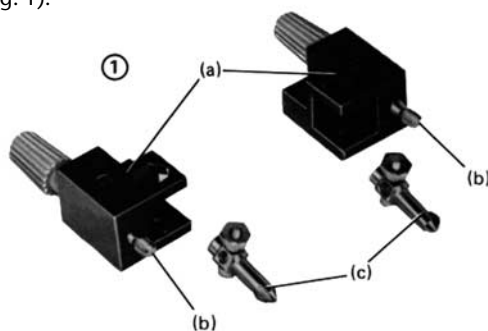

Dimensions (mm) – See fig. 2						
Number of contacts	17	29	33	41	53	65
Dimension A*	44.08	59.32	64.40	74.56	89.80	105.04
Dimension B*	30.48	45.72	50.80	60.96	76.20	91.44

* A: dimension between the locking rods

B: dimension between the fittings

How to order

1 set of locking systems for male plug: **12 522**

1 set of locking systems for female plug: **21 351**

Plugs equipped with locking systems mate with receptacles equipped with screwlock sockets.

Screwlock sockets for HE 804 receptacles

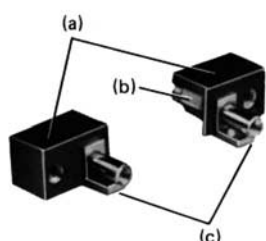
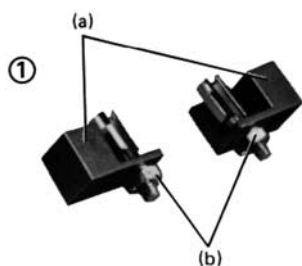

These screwlock sockets allow the mating of HE 804 receptacles with plugs equipped with hoods (refer to page 12) or locking systems (see above).

They are available in 2 versions:

- for perpendicular mounting to a chassis or a motherboard
- with brackets, for receptacles fitted with right angled contacts, mounted on the edge of a daughter board

These screwlock sockets are used with HE 804 receptacles:

- without fittings
- fitted with 17, 29, 33, 41, 53 or 65 pin or socket contacts
- equipped with Z, ZC, YD, Y, W3 or X contacts for sockets without brackets and YC contacts for sockets with brackets

A set of screwlock sockets is composed of the following parts (see fig. 1):

- 2 thermoplastic blocks (a) to be mounted at the extremities of the receptacle. The inner metal tapped parts allow the locking of the plug equipped with a hood or a locking system
- 2 fittings (b) with or without brackets (c) to mount the receptacle on the panel. They mate with the fitting of the plug

The working temperature is - 40°C to + 125°C.

How to order

1 set of screwlock sockets **without brackets** for male or female receptacle: **21 347**

1 set of screwlock sockets **with brackets** for male or female receptacle: **21 349**

Dimensions

Fig. 1: sockets without brackets

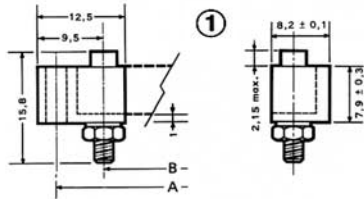
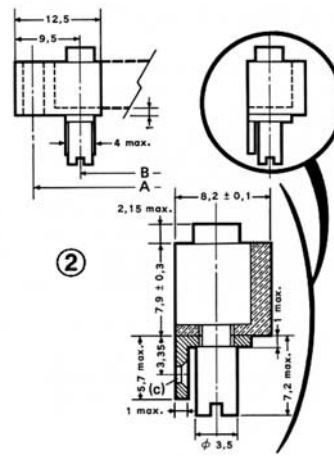

Fig. 2: sockets with brackets (c) hole Ø 1.6 with 90° milling



Panel drilling

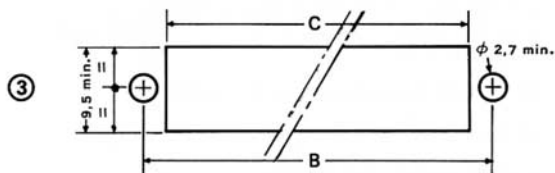

Fig. 3: for receptacles and screwlock sockets without brackets
max. panel thickness: 3.2 mm

Printed circuit board drilling

Motherboards with receptacles and screwlock sockets without brackets

Fig. 4: for male receptacles with Y contacts max.
panel thickness: 3.2 mm

Fig. 5: for female receptacles with YD contacts max.
panel thickness: 2.4 mm

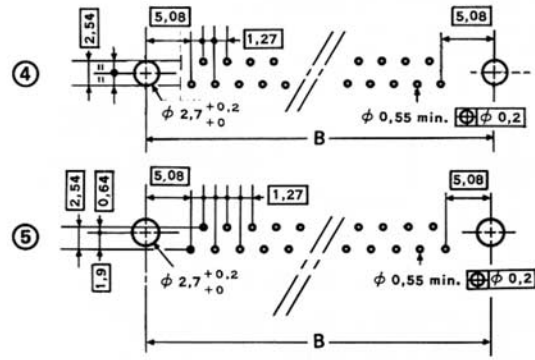

Daughterboards with receptacles and screwlock sockets with brackets

Fig. 6: for male or female receptacles with YC contacts

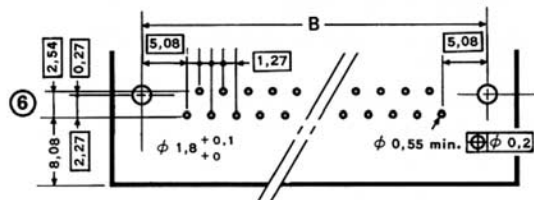

Note:

The board is illustrated from the connector side

Dimensions (mm)						
Number of contacts	17	29	33	41	53	65
Dimension A*	44.08	59.32	64.40	74.56	89.80	105.04
Dimension B*	30.48	45.72	50.80	60.96	76.20	91.44
Dimension C*	25.90	41.10	46.20	56.40	71.60	86.90

* A: dimension between the locking rods
B: dimension between the fittings

HE 801 – HE 804 3-row female plugs

Series (3 rows)	127 T 144	A	F	-	1	YC	N	-
Number of contacts (refer to p. 2) 80, 144								
Fittings (refer to p. 4 - 5) A, D, AS, PA, KE, KED: for plugs with 80 contacts A, AS, D, PA, E: for plugs with 144 contacts XL: without fitting (please order fittings separately - refer to p. 19)								
Contacts F: socket contacts								
Fittings material Blank: nickel plated brass 1: stainless steel								
Professional and military class (1µm gold over nickel on contact area) 1: tinned plating on YC and Z terminations								
Contact type YC, Z, T								
Model N: HE 801 Blank: HE 804								
Cavities marking Blank: normal (plug marking) B: reversed marking (receptacle marking)								

Underlined elements: recommended versions

HE 801 – HE 804 3-row male receptacles

Series (3 rows)	127 T 144	A	M	-	1	W3	R	-
Number of contacts (refer to p. 2) 80, 144								
Fittings (refer to p. 4 - 5) A, B, D, AD, AT X: without fitting (please order fittings separately - refer to p.19)								
Contacts M: pin contacts								
Fittings material Blank: nickel plated brass 1: stainless steel								
Professional and military class (1 µm gold over nickel on contact area) 1: tinned plating on Y, YC and ZC terminations gold plating on W3 and X terminations 6: tinned plating on W3 terminations								
Contact type Y, W3, ZC								
Model R: HE 801 Blank: HE 804								
Cavities marking Blank: normal (receptacle marking) B: reversed marking (plug marking)								

Underlined elements: recommended versions

HE 801 – HE 804 2-row female plugs

Series (2 rows)	127	17	A	F	-	1	YC	N	-
Number of contacts (refer to p. 2)	<u>17,29,33,41,53,65,72,84,96</u>								
Fittings (refer to p. 4 - 5)	A, PA, AS, D, N, H (for HE 804 only), E, NF, NS, EF, ES, ET, V								
	XL : without fitting (please order fittings separately - refer to p. 19)								
Contacts	F : socket contacts								
Fittings material	Blank : nickel plated brass 1 : stainless steel								
Professional and military class	(1 µm gold over nickel on contact area) 1 : tinned plating on YC, Y, Z, T, U and YL terminations gold plating on W3 and X1 terminations 6 : tinned plating on W3 terminations								
Contact type	YC, U, T : for free plugs W3, Z, YD, Y, X1 : for fixed plugs								
Model	N : HE 801 Blank : HE 804								
Cavities marking	Blank : normal (plug marking) B : reversed marking (receptacle marking)								

Underlined elements: recommended versions

HE 801 – HE 804 2-row male receptacles

Series (2 rows)	127	96	A	M	-	1	ZC	R	-
Number of contacts (refer to p. 2)	<u>17,29,33,41,53,65,72,84,96</u>								
Fittings (refer to p. 4 - 5)	A, B, AE, D, DC, AD AED, AT, AET								
	X : without fitting (please order fittings separately - refer to page 19)								
Contacts	M : pin contacts								
Fittings material	Blank : nickel plated brass 1 : stainless steel								
Professional and military class	(1 µm gold over nickel on contact area) 1 : tinned plating on Y, YC, ZC, and YL terminations gold plating on W3 and X terminations 6 : tinned plating on W3 terminations								
Contact type	YC : for free receptacles W3, ZC, Y, X : for fixed receptacles								
Model	R : HE 801 Blank : HE 804								
Cavities marking	Blank : normal (receptacle marking) B : reversed marking (plug marking)								

Underlined elements: recommended versions

HE 801 – HE 804 2-row male plugs

Series (2 rows)	127	96	J	M	-	1	YC	R	-
Number of contacts (refer to p. 2)	17,29,33,41,53,65,72,84,96								
Fittings (refer to p. 4 - 5)	J, PC, JS, S, N, R, NF, NS, RF, RS, RT, V								
	XL : without fitting (please order fittings separately - refer to p. 19)								
Contacts	M : pin contacts								
Fittings material	Blank : nickel plated brass								
	1 : stainless steel								
Professional and military class	(1 µm gold over nickel on contact area)								
	1 : tinned plating on YC, Y, ZC, U and YL terminations gold plating on W3 and X terminations								
	6 : tinned plating on W3 terminations								
Contact type	YC, U : for free plugs								
	W3, ZC, Y, X : for fixed plugs								
Model	R : HE 801								
	Blank : HE 804								
Cavities marking	Blank : normal (plug marking)								
	B : reversed marking (receptacle marking)								

Underlined elements: recommended versions**HE 801 – HE 804 2-row female receptacles**

Series (2 rows)	127	29	K	F	-	1	Y	N	-
Number of contacts (refer to p. 2)	17,29,33,41,53,65,72,84,96								
Fittings (refer to p. 4 - 5)	K, P, KE, S, SC, KD, KED, KT, KET								
	X : without-fitting (please order fittings separately - refer to p.19)								
Contacts	F : socket contacts								
Fittings material	Blank : nickel plated brass								
	1 : stainless steel								
Professional and military class	(1 µm gold over nickel on contact area)								
	1 : tinned plating on YD, Y, Z, YC and YL terminations gold plating on W3 and X1 terminations								
	6 : tinned plating on W3 terminations								
Contact type	YC : for free receptacles								
	W3, YD, Y, Z, X1 : for fixed receptacles								
Model	N : HE 801								
	Blank : HE 804								
Cavities marking	Blank : normal (receptacle marking)								
	B : reversed marking (plug marking)								

Underlined elements: recommended versions

HE 807 male or female plugs

Series	127 H	29	A	F	-	1	YC	N	3A	-
Number of signal contacts (refer to p. 2) <u>5,17,29,41,48,56,60,72</u> : symmetrical arrangements <u>5,17,29,41,53,60,72,84</u> : asymmetrical arrangements										
Fittings (refer to p. 4 - 5) <u>A,AS,D,E,EF,ES,ET,PA,T</u> <u>XL</u> : without fitting (please order fittings separately - refer to p.19)										
Contacts F : socket contacts M : pin contacts										
Fittings material Blank : nickel plated brass 1 : stainless steel										
Professional and military class (1 µm gold over nickel on contact area) 1 : tinned plating on YC, Y, Z, ZC and YL terminations gold plating on W3, X and X1 terminations 6 : tinned plating on W3 terminations										
Contact type YC, W3, X, X1, Z, ZC,Y, T										
HE 807 model N : Socket contacts R : Pin contacts										
Number of cavities for power, coaxial or optical contacts 3A : 3 cavities 6A : 6 cavities 10A : 10 cavities (please order power, coaxial and optical contacts separately - refer to pages 6 to 8)										
Contact marking Blank : normal (plug marking) B : reversed marking (receptacle marking) Note: The asymmetrical arrangements ever have reversed marking on male plugs										
Underlined elements : recommended versions										

HE 807 male or female receptacles

Series	127 H	29	A	F	-	1	YC	N	3A	-
Number of signal contacts (refer to p. 2) 5,17,29,41,48,56,60,72: symmetrical arrangements 5,17,29,41,53,60,72,84: asymmetrical arrangements										
Fittings (refer to p. 4 - 5) IE,K,KE,KED,KET,KD,KT,P,S X: without fitting (please order fittings separately - refer to p. 19)										
Contacts F: socket contacts M: pin contacts										
Fittings material Blank: nickel plated brass 1: stainless steel										
Professional and military class (1 µm gold over nickel on contact area) 1: tinned plating on YC, Y, Z, ZC and YL terminations gold plating on W3, X and X1 terminations 6: tinned plating on W3 terminations										
Contact type YC, W3, X, X1, Z, ZC, Y										
HE 807 model N: Socket contacts R: Pin contacts										
Number of cavities for power, coaxial or optical contacts 3A: 3 cavities 6A: 6 cavities 10A: 10 cavities (please order power, coaxial and optical contacts separately - refer to pages 6 to 8)										
Contact marking Blank: normal (plug marking) B: reversed marking (receptacle marking) Note: The asymmetrical arrangements ever have reversed marking on female receptacles										

Underlined elements: recommended versions

HE 807 plugs without signal contacts

Insert with 7 cavities for specific contacts without fittings

127 H 0 XL 0 1 00 H 7A

Insert with 8 cavities for specific contacts without fittings (recommended for fiber optical applications)

127 H 0 XL 0 1 00 H 8A

HE 807 receptacles without signal contacts

Insert with 7 cavities for specific contacts without fittings

127 H 0 X 0 1 00 H 7A

Insert with 8 cavities for specific contacts without fittings (recommended for fiber optical applications)

127 H 0 X 0 1 00 H 8A

Fittings (for connectors ordered without fitting: XL or X)

Fitting	HE 8 C	101
Fitting type 1XX: male for plug - nickel plated brass 2XX: female for receptacle - nickel plated brass 3XX: male for plug - stainless steel 4XX: female for receptacle - stainless steel For XX, please refer to charts on pages 4 and 5 (HE8C P/N)		

Cross references chart HE 804 / 127

Connectors with 2 fitting locations (17, 29, 41, 53 and 65 contacts)

Connectors with fittings		Connectors without fitting + 2 separate fittings		Connectors with fittings		Connectors without fitting + 2 separate fittings	
HE 804 references	Amphenol P/N	Amphenol P/N	and brass or stainless steel fittings	HE 804 references	Amphenol P/N	Amphenol P/N	and brass or stainless steel fittings
HE 804 ES 17 S1 1 A 000 2	127 17 X F 1X1	127 17 XL F 1X1	and HE 8 C 110 or HE 8 C 310	HE 804 FP 17 Y 1 A 000 3	127 17 XL M 1YC	127 17 XL M 1YC	and HE 8 C 101 or HE 8 C 301
HE 804 FS 17 S1 1 A 110 2	127 17 E F 1X1	127 17 XL F 1X1	and HE 8 C 112 or HE 8 C 312	HE 804 FP 17 Y 1 A 101 3	127 17 J M 1YC	127 17 XL M 1YC	and HE 8 C 102 or HE 8 C 302
HE 804 FS 17 S1 1 A 125 2	127 17 EF F 1X1	127 17 XL F 1X1	and HE 8 C 125 or HE 8 C 325	HE 804 FP 17 Y 1 A 103 3	127 17 PC M 1YC	127 17 XL M 1YC	and HE 8 C 103 or HE 8 C 303
HE 804 ES 17 S1 1 A 201 2	127 17 K F 1X1	127 17 X F 1X1	and HE 8 C 201 or HE 8 C 401	HE 804 EP 17 Y 1 A 209 3	127 17 S M 1YC	127 17 X M 1YC	and HE 8 C 209 or HE 8 C 409
HE 804 EN 17 S2 1 A 000 2	127 17 X M 1X	127 17 XL M 1X	and HE 8 C 110 or HE 8 C 310	HE 804 ES 17 Y 0 A 000 3	127 17 X F 1YD	127 17 XL F 1YD	and HE 8 C 110 or HE 8 C 310
HE 804 FN 17 S2 1 A 110 2	127 17 R M 1X	127 17 XL M 1X	and HE 8 C 112 or HE 8 C 312	HE 804 FS 17 Y 0 A 110 3	127 17 E F 1YD	127 17 XL F 1YD	and HE 8 C 112 or HE 8 C 312
HE 804 FN 17 S2 1 A 112 2	127 17 RF M 1X	127 17 XL M 1X	and HE 8 C 125 or HE 8 C 325	HE 804 FS 17 Y 0 A 112 3	127 17 EF F 1YD	127 17 XL F 1YD	and HE 8 C 125 or HE 8 C 325
HE 804 FN 17 S2 1 A 125 2	127 17 RS M 1X	127 17 X M 1X	and HE 8 C 201 or HE 8 C 401	HE 804 FS 17 Y 0 A 125 3	127 17 ES F 1YD	127 17 X F 1YD	and HE 8 C 201 or HE 8 C 401
HE 804 EN 17 S2 1 A 201 2	127 17 A M 1X	127 17 X M 1X	and HE 8 C 203 or HE 8 C 403	HE 804 ES 17 Y 0 A 201 3	127 17 K F 1YD	127 17 X F 1YD	and HE 8 C 203 or HE 8 C 403
HE 804 EN 17 S2 1 A 203 2	127 17 B M 1X	127 17 X M 1X	and HE 8 C 220 or HE 8 C 420	HE 804 ES 17 Z 1 A 000 3	127 17 X F 1Z	127 17 XL F 1Z	and HE 8 C 110 or HE 8 C 310
HE 804 EN 17 S2 1 A 220 2	127 17 D M 1X	127 17 X M 1X	and HE 8 C 110 or HE 8 C 310	HE 804 FS 17 Z 1 A 110 3	127 17 E F 1Z	127 17 XL F 1Z	and HE 8 C 112 or HE 8 C 312
HE 804 ES 17 W 0 A 000 2	127 17 X F 1W3	127 17 XL F 1W3	and HE 8 C 110 or HE 8 C 310	HE 804 FS 17 Z 1 A 112 3	127 17 EF F 1Z	127 17 XL F 1Z	and HE 8 C 125 or HE 8 C 325
HE 804 FS 17 W 0 A 110 2	127 17 E F 1W3	127 17 XL F 1W3	and HE 8 C 112 or HE 8 C 312	HE 804 FS 17 Z 1 A 125 3	127 17 ES F 1Z	127 17 X F 1Z	and HE 8 C 201 or HE 8 C 401
HE 804 FS 17 W 0 A 112 2	127 17 EF F 1W3	127 17 X F 1W3	and HE 8 C 201 or HE 8 C 401	HE 804 ES 17 Z 1 A 201 3	127 17 K F 1Z	127 17 X F 1Z	and HE 8 C 110 or HE 8 C 310
HE 804 FS 17 W 0 A 125 2	127 17 ES F 1W3	127 17 X F 1W3	and HE 8 C 110 or HE 8 C 310	HE 804 EN 17 Z 1 A 000 3	127 17 X M 1ZC	127 17 XL M 1ZC	and HE 8 C 112 or HE 8 C 312
HE 804 ES 17 W 0 A 201 2	127 17 K F 1W3	127 17 X F 1W3	and HE 8 C 125 or HE 8 C 325	HE 804 FN 17 Z 1 A 110 3	127 17 R M 1ZC	127 17 XL M 1ZC	and HE 8 C 125 or HE 8 C 325
HE 804 EN 17 W 0 A 000 2	127 17 X M 1W3	127 17 XL M 1W3	and HE 8 C 110 or HE 8 C 310	HE 804 FN 17 Z 1 A 112 3	127 17 RF M 1ZC	127 17 XL M 1ZC	and HE 8 C 125 or HE 8 C 325
HE 804 FN 17 W 0 A 110 2	127 17 R M 1W3	127 17 XL M 1W3	and HE 8 C 112 or HE 8 C 312	HE 804 FN 17 Z 1 A 125 3	127 17 RS M 1ZC	127 17 X M 1ZC	and HE 8 C 201 or HE 8 C 401
HE 804 FN 17 W 0 A 112 2	127 17 RF M 1W3	127 17 X M 1W3	and HE 8 C 125 or HE 8 C 325	HE 804 FN 17 Z 1 A 201 3	127 17 A M 1ZC	127 17 X M 1ZC	and HE 8 C 203 or HE 8 C 403
HE 804 FN 17 W 0 A 125 2	127 17 RS M 1W3	127 17 X M 1W3	and HE 8 C 201 or HE 8 C 401	HE 804 EN 17 Z 1 A 203 3	127 17 B M 1ZC	127 17 X M 1ZC	and HE 8 C 220 or HE 8 C 420
HE 804 EN 17 W 0 A 201 2	127 17 A M 1W3	127 17 X M 1W3	and HE 8 C 203 or HE 8 C 403	HE 804 EN 17 Z 1 A 220 3	127 17 D M 1ZC	127 17 X M 1ZC	and HE 8 C 110 or HE 8 C 310
HE 804 EN 17 W 0 A 203 2	127 17 B M 1W3	127 17 X M 1W3	and HE 8 C 110 or HE 8 C 310	HE 804 FC 17 U 1 A 000 3	127 17 XL F 1U	127 17 XL F 1U	and HE 8 C 106 or HE 8 C 306
HE 804 EN 17 W 0 A 220 2	127 17 D M 1W3	127 17 X M 1W3	and HE 8 C 112 or HE 8 C 312	HE 804 FC 17 U 1 A 106 3	127 17 N F 1U	127 17 XL F 1U	and HE 8 C 108 or HE 8 C 308
HE 804 EN 17 Y 0 A 000 3	127 17 X M 1Y	127 17 XL M 1Y	and HE 8 C 110 or HE 8 C 310	HE 804 FC 17 U 1 A 108 3	127 17 NF F 1U	127 17 X F 1U	and HE 8 C 107 or HE 8 C 307
HE 804 FN 17 Y 0 A 110 3	127 17 R M 1Y	127 17 XL M 1Y	and HE 8 C 112 or HE 8 C 312	HE 804 FD 17 U 1 A 000 3	127 17 XL F 1U	127 17 X F 1U	and HE 8 C 109 or HE 8 C 309
HE 804 FN 17 Y 0 A 112 3	127 17 RF M 1Y	127 17 X M 1Y	and HE 8 C 125 or HE 8 C 325	HE 804 FD 17 U 1 A 107 3	127 17 H F 1U	127 17 X F 1U	and HE 8 C 105 or HE 8 C 305
HE 804 FN 17 Y 0 A 125 3	127 17 RS M 1Y	127 17 X M 1Y	and HE 8 C 201 or HE 8 C 401	HE 804 FD 17 U 1 A 109 3	127 17 HF F 1U	127 17 X F 1U	and HE 8 C 106 or HE 8 C 306
HE 804 EN 17 Y 0 A 201 3	127 17 A M 1Y	127 17 X M 1Y	and HE 8 C 203 or HE 8 C 403	HE 804 FD 17 U 1 A 105 3	127 17 G F 1U	127 17 X F 1U	and HE 8 C 108 or HE 8 C 308
HE 804 EN 17 Y 0 A 203 3	127 17 B M 1Y	127 17 X M 1Y	and HE 8 C 203 or HE 8 C 403	HE 804 FB 17 U 0 A 000 3	127 17 XL M 1U	127 17 XL M 1U	and HE 8 C 106 or HE 8 C 306
HE 804 FB 17 Y 1 A 000 3	127 17 XL F 1YC	127 17 XL F 1YC	and HE 8 C 101 or HE 8 C 301	HE 804 FB 17 U 0 A 106 3	127 17 N M 1U	127 17 XL M 1U	and HE 8 C 108 or HE 8 C 308
HE 804 FB 17 Y 1 A 101 3	127 17 A F 1YC	127 17 XL F 1YC	and HE 8 C 102 or HE 8 C 302	HE 804 FB 17 U 0 A 108 3	127 17 NF M 1U	127 17 XL M 1U	and HE 8 C 104 or HE 8 C 304
HE 804 FB 17 Y 1 A 102 3	127 17 PA F 1YC	127 17 X F 1YC	and HE 8 C 103 or HE 8 C 303	HE 804 FB 17 U 0 A 104 3	127 17 V M 1U	127 17 X F 1YC	and HE 8 C 209 or HE 8 C 409
HE 804 FB 17 Y 1 A 103 3	127 17 D F 1YC	127 17 X F 1YC	and HE 8 C 209 or HE 8 C 409				
HE 804 EB 17 Y 1 A 209 3	127 17 KE F 1YC	127 17 X F 1YC	and HE 8 C 209 or HE 8 C 409				

Connectors with 3 fitting locations (72, 84 and 96 contacts)

HE 804 references	Amphenol P/N (no fitting)	Amphenol P/N (no fitting)	and brass or stainless steel 2 extremity + 1 central fittings	HE 804 references	Amphenol P/N (no fitting)	Amphenol P/N (no fitting)	and brass or stainless steel 2 extremity + 1 central fittings
HE 804 ES 72 S1 1 A 000 2	127 72 X F 1X1	127 72 XL F 1X1	and ... 110 + ... 113 or ... 310 + ... 313	HE 804 FS 72 Z 1 B 112 3	127 72 EF F 1Z	127 72 XL F 1Z	and ... 112 + ... 113 or ... 312 + ... 313
HE 804 FS 72 S1 1 A 110 2	127 72 E F 1X1	127 72 XL F 1X1	and ... 112 + ... 113 or ... 312 + ... 313	HE 804 FS 72 Z 1 B 125 3	127 72 ES F 1Z	127 72 XL F 1Z	and ... 125 + ... 113 or ... 325 + ... 313
HE 804 FS 72 S1 1 A 112 2	127 72 EF F 1X1	127 72 XL F 1X1	and ... 125 + ... 113 or ... 325 + ... 313	HE 804 ES 72 Z 1 B 201 3	127 72 K F 1Z	127 72 X F 1Z	and ... 201 + ... 202 or ... 401 + ... 402
HE 804 FS 72 S1 1 A 125 2	127 72 ES F 1X1	127 72 X F 1X1	and ... 201 + ... 202 or ... 401 + ... 402	HE 804 EN 72 Z 1 B 000 3	127 72 X M 1ZC	127 72 XL M 1ZC	and ... 110 + ... 113 or ... 310 + ... 313
HE 804 ES 72 S1 1 A 201 2	127 72 K F 1X1	127 72 X F 1X1	and ... 110 + ... 113 or ... 310 + ... 313	HE 804 FN 72 Z 1 B 110 3	127 72 R M 1ZC	127 72 XL M 1ZC	and ... 112 + ... 113 or ... 312 + ... 313
HE 804 EN 72 S2 1 A 000 2	127 72 X M 1X	127 72 XL M 1X	and ... 112 + ... 113 or ... 312 + ... 313	HE 804 FN 72 Z 1 B 112 3	127 72 RF M 1ZC	127 72 XL M 1ZC	and ... 113 + ... 113 or ... 325 + ... 313
HE 804 FN 72 S2 1 A 110 2	127 72 R M 1X	127 72 XL M 1X	and ... 125 + ... 113 or ... 325 + ... 313	HE 804 FN 72 Z 1 B 125 3	127 72 RS M 1ZC	127 72 X M 1ZC	and ... 201 + ... 202 or ... 401 + ... 402
HE 804 FN 72 S2 1 A 112 2	127 72 RF M 1X	127 72 X M 1X	and ... 201 + ... 202 or ... 401 + ... 402	HE 804 EN 72 Z 1 B 201 3	127 72 A M 1ZC	127 72 X M 1ZC	and ... 203 + ... 202 or ... 403 + ... 402
HE 804 FN 72 S2 1 A 125 2	127 72 RS M 1X	127 72 X M 1X	and ... 203 + ... 202 or ... 403 + ... 402	HE 804 EN 72 Z 1 B 203 3	127 72 B M 1ZC	127 72 X M 1ZC	and ... 220 + ... 202 or ... 420 + ... 402
HE 804 EN 72 S2 1 A 201 2	127 72 A M 1X	127 72 X M 1X	and ... 220 + ... 202 or ... 420 + ... 402	HE 804 EN 72 Z 1 B 220 3	127 72 D M 1ZC	127 72 X M 1ZC	and ... 110 + ... 113 or ... 310 + ... 313
HE 804 EN 72 S2 1 A 203 2	127 72 B M 1X	127 72 X M 1X	and ... 110 + ... 113 or ... 310 + ... 313	HE 804 ES 72 W 0 A 000 2	127 72 X FA 1W3	127 72 XL FA 1W3	and ... 113 + ... 113 or ... 312 + ... 313
HE 804 EN 72 S2 1 A 220 2	127 72 D M 1X	127 72 X M 1X	and ... 112 + ... 113 or ... 312 + ... 313	HE 804 FS 72 W 0 A 112 2	127 72 EF FA 1W3	127 72 XL FA 1W3	and ... 113 + ... 113 or ... 325 + ... 313
HE 804 ES 72 W 0 B 000 2	127 72 X F 1W3	127 72 XL F 1W3	and ... 112 + ... 113 or ... 312 + ... 313	HE 804 FS 72 W 0 A 125 2	127 72 S FA 1W3	127 72 X FA 1W3	and ... 202 + ... 202 or ... 401 + ... 402
HE 804 FS 72 W 0 B 110 2	127 72 E F 1W3	127 72 XL F 1W3	and ... 125 + ... 113 or ... 325 + ... 313	HE 804 ES 72 W 0 A 201 2	127 72 K FA 1W3	127 72 X FA 1W3	and ... 201 + ... 202 or ... 401 + ... 402
HE 804 FS 72 W 0 B 112 2	127 72 EF F 1W3	127 72 X F 1W3	and ... 201 + ... 202 or ... 401 + ... 402	HE 804 EN 72 W 0 A 000 2	127 72 X MA 1W3	127 72 XL MA 1W3	and ... 113 + ... 113 or ... 310 + ... 313
HE 804 FS 72 W 0 B 125 2	127 72 ES F 1W3	127 72 X F 1W3	and ... 112 + ... 113 or ... 312 + ... 313	HE 804 FN 72 W 0 A 110 2	127 72 R MA 1W3	127 72 XL MA 1W3	and ... 113 + ... 113 or ... 311 + ... 313
HE 804 ES 72 W 0 B 201 2	127 72 K F 1W3	127 72 X F 1W3	and ... 201 + ... 202 or ... 401 + ... 402	HE 804 FN 72 W 0 A 111 2	127 72 T MA 1W3	127 72 XL MA 1W3	and ... 113 + ... 113 or ... 312 + ... 313
HE 804 EN 72 W 0 B 000 2	127 72 X M 1W3	127 72 XL M 1W3	and ... 110 + ... 113 or ... 310 + ... 313	HE 804 FN 72 W 0 A 112 2	127 72 RF MA 1W3	127 72 XL MA 1W3	and ... 113 + ... 113 or ... 312 + ... 313
HE 804 FN 72 W 0 B 110 2	127 72 R M 1W3	127 72 XL M 1W3	and ... 112 + ... 113 or ... 312 + ... 313	HE 804 FN 72 W 0 A 125 2	127 72 RS MA 1W3	127 72 X M 1W3	and ... 113 + ... 113 or ... 325 + ... 313
HE 804 FN 72 W 0 B 112 2	127 72 RF M 1W3	127 72 X M 1W3	and ... 125 + ... 113 or ... 325 + ... 313	HE 804 EN 72 W 0 A 201 2	127 72 A MA 1W3	127 72 X MA 1W3	and ... 202 + ... 202 or ... 401 + ... 402
HE 804 FN 72 W 0 B 125 2	127 72 RS M 1W3	127 72 X M 1W3	and ... 201 + ... 202 or ... 401 + ... 402	HE 804 EN 72 W 0 A 220 2	127 72 D MA 1W3	127 72 X MA 1W3	and ... 202 + ... 202 or ... 420 + ... 402
HE 804 EN 72 W 0 B 201 2	127 72 A M 1W3	127 72 X M 1W3	and ... 203 + ... 202 or ... 403 + ... 402	HE 804 ES 72 Z 1 A 000 3	127 72 X FA 1Z	127 72 XL FA 1Z	and ... 110 + ... 113 or ... 310 + ... 313
HE 804 EN 72 W 0 B 203 2	127 72 B M 1W3	127 72 X M 1W3	and ... 220 + ... 202 or ... 420 + ... 402	HE 804 FS 72 Z 1 A 110 3	127 72 E FA 1Z	127 72 XL FA 1Z	and ... 112 + ... 113 or ... 312 + ... 313
HE 804 EN 72 W 0 B 220 2	127 72 D M 1W3	127 72 X M 1W3	and ... 110 + ... 113 or ... 310 + ... 313	HE 804 FS 72 Z 1 A 112 3	127 72 F FA 1Z	127 72 XL FA 1Z	and ... 125 + ... 113 or ... 325 + ... 313
HE 804 EN 72 Y 0 A 000 3	127 72 X M 1Y	127 72 XL M 1Y	and ... 112 + ... 113 or ... 312 + ... 313	HE 804 FS 72 Z 1 A 125 3	127 72 ES FA 1Z	127 72 X FA 1Z	and ... 201 + ... 202 or ... 401 + ... 402
HE 804 FN 72 Y 0 A 110 3	127 72 R M 1Y	127 72 XL M 1Y	and ... 125 + ... 113 or ... 325 + ... 313	HE 804 ES 72 Z 1 A 201 3	127 72 K FA 1Z	127 72 X FA 1Z	and ... 201 + ... 202 or ... 401 + ... 402
HE 804 FN 72 Y 0 A 112 3	127 72 RF M 1Y	127 72 X M 1Y	and ... 201 + ... 202 or ... 401 + ... 402	HE 804 EN 72 Z 1 A 000 3	127 72 X MA 1ZC	127 72 XL MA 1ZC	and ... 110 + ... 113 or ... 310 + ... 313
HE 804 FN 72 Y 0 A 125 3	127 72 RS M 1Y	127 72 X M 1Y	and ... 112 + ... 113 or ... 312 + ... 313	HE 804 FN 72 Z 1 A 110 3	127 72 R MA 1ZC	127 72 XL MA 1ZC	and ... 112 + ... 113 or ... 312 + ... 313
HE 804 EN 72 Y 0 A 201 3	127 72 A M 1Y	127 72 X M 1Y	and ... 125 + ... 113 or ... 325 + ... 313	HE 804 FN 72 Z 1 A 112 3	127 72 RF MA 1ZC	127 72 XL MA 1ZC	and ... 113 + ... 113 or ... 312 + ... 313
HE 804 EN 72 Y 0 A 203 3	127 72 B M 1Y	127 72 X M 1Y	and ... 201 + ... 202 or ... 401 + ... 402	HE 804 FN 72 Z 1 A 125 3	127 72 RS MA 1ZC	127 72 X MA 1ZC	and ... 125 + ... 113 or ... 325 + ... 313
HE 804 FB 72 Y 1 A 000 3	127 72 XL F 1YC	127 72 XL F 1YC	and ... 101 + ... 102 or ... 301 + ... 302	HE 804 EN 72 Z 1 A 201 3	127 72 A MA 1ZC	127 72 X MA 1ZC	and ... 201 + ... 202 or ... 401 + ... 402
HE 804 FB 72 Y 1 A 101 3	127 72 A F 1YC	127 72 XL F 1YC	and ... 102 + ... 102 or ... 302 + ... 302	HE 804 EN 72 Z 1 A 203 3	1		

Cross references chart HE 807 / 127 H

Connectors with 2 fitting locations						
Connectors with fittings		Connectors without fitting	+	2 separate fittings		
HE 807 references	Amphenol P/N	Amphenol P/N without fitting	and	2 brass fittings	or	2 stainless steel fittings
ASYMETRICAL ARRANGEMENTS						
HE 807 FB 17 Y 1 A 3 000 3	127 H 17 XL F 1 YC N 3A	127 H 17 XL F 1 YC N 3A				
HE 807 FB 17 Y 1 A 3 101 3	127 H 17 A F 1 YC N 3A	127 H 17 XL F 1 YC N 3A	and	HE8C 101	or	HE8C 301
HE 807 FB 17 Y 1 A 3 102 3	127 H 17 PA F 1 YC N 3A	127 H 17 XL F 1 YC N 3A	and	HE8C 102	or	HE8C 302
HE 807 FB 17 Y 1 A 3 103 3	127 H 17 D F 1 YC N 3A	127 H 17 XL F 1 YC N 3A	and	HE8C 103	or	HE8C 303
HE 807 FB 17 Y 1 A 3 206 3	127 H 17 IE F 1 YC N 3AB	127 H 17 XL F 1 YC N 3A	and	HE8C 206	or	HE8C 406
HE 807 FB 17 Y 1 A 3 208 3	127 H 17 KE F 1 YC N 3AB	127 H 17 XL F 1 YC N 3A	and	HE8C 208	or	HE8C 408
HE 807 EP 17 Y 1 A 3 000 3	127 H 17 X M 1 YC R 3A	127 H 17 X M 1 YC R 3A				
HE 807 EP 17 Y 1 A 3 101 3	127 H 17 A M 1 YC R 3AB	127 H 17 X M 1 YC R 3A	and	HE8C 101	or	HE8C 301
HE 807 EP 17 Y 1 A 3 102 3	127 H 17 PA M 1 YC R 3AB	127 H 17 X M 1 YC R 3A	and	HE8C 102	or	HE8C 302
HE 807 EP 17 Y 1 A 3 103 3	127 H 17 D M 1 YC R 3AB	127 H 17 X M 1 YC R 3A	and	HE8C 103	or	HE8C 303
HE 807 EP 17 Y 1 A 3 206 3	127 H 17 IE M 1 YC R 3A	127 H 17 X M 1 YC R 3A	and	HE8C 206	or	HE8C 406
HE 807 EP 17 Y 1 A 3 208 3	127 H 17 KE M 1 YC R 3A	127 H 17 X M 1 YC R 3A	and	HE8C 208	or	HE8C 408
HE 807 FS 17 W 0 A 3 000 2	127 H 17 XL F 1 W3 N 3A	127 H 17 XL F 1 W3 N 3A				
HE 807 FS 17 W 0 A 3 117 2	127 H 17 E F 1 W3 N 3A	127 H 17 XL F 1 W3 N 3A	and	HE8C 117	or	HE8C 317
HE 807 FS 17 W 0 A 3 212 2	127 H 17 K F 1 W3 N 3AB	127 H 17 XL F 1 W3 N 3A	and	HE8C 212	or	HE8C 412
HE 807 FS 17 W 0 A 3 213 2	127 H 17 S F 1 W3 N 3AB	127 H 17 XL F 1 W3 N 3A	and	HE8C 213	or	HE8C 413
HE 807 FS 17 W 0 A 3 226 2	127 H 17 P F 1 W3 N 3AB	127 H 17 XL F 1 W3 N 3A	and	HE8C 226	or	HE8C 426
HE 807 EN 17 W 0 A 3 000 2	127 H 17 X M 1 W3 R 3A	127 H 17 X M 1 W3 R 3A				
HE 807 EN 17 W 0 A 3 212 2	127 H 17 K M 1 W3 R 3A	127 H 17 X M 1 W3 R 3A	and	HE8C 212	or	HE8C 412
HE 807 EN 17 W 0 A 3 213 2	127 H 17 S M 1 W3 R 3A	127 H 17 X M 1 W3 R 3A	and	HE8C 213	or	HE8C 413
HE 807 EN 17 W 0 A 3 117 2	127 H 17 E M 1 W3 R 3AB	127 H 17 X M 1 W3 R 3A	and	HE8C 117	or	HE8C 317
HE 807 EN 17 Y 0 A 3 000 3	127 H 17 X M 1 Y R 3A	127 H 17 X M 1 Y R 3A				
HE 807 EN 17 Y 0 A 3 212 3	127 H 17 K M 1 Y R 3A	127 H 17 X M 1 Y R 3A	and	HE8C 212	or	HE8C 412
HE 807 EN 17 Y 0 A 3 213 3	127 H 17 S M 1 Y R 3A	127 H 17 X M 1 Y R 3A	and	HE8C 213	or	HE8C 413
HE 807 EN 17 Y 0 A 3 117 3	127 H 17 E M 1 Y R 3AB	127 H 17 X M 1 Y R 3A	and	HE8C 117	or	HE8C 317
HE 807 FS 17 Y 0 A 3 000 3	127 H 17 XL F 1 Y N 3A	127 H 17 XL F 1 Y N 3A				
HE 807 FS 17 Y 0 A 3 117 3	127 H 17 E F 1 Y N 3A	127 H 17 XL F 1 Y N 3A	and	HE8C 117	or	HE8C 317
HE 807 FS 17 Y 0 A 3 212 3	127 H 17 K F 1 Y N 3AB	127 H 17 XL F 1 Y N 3A	and	HE8C 212	or	HE8C 412
HE 807 FS 17 Y 0 A 3 213 3	127 H 17 S F 1 Y N 3AB	127 H 17 XL F 1 Y N 3A	and	HE8C 213	or	HE8C 413
HE 807 EN 17 Z 1 A 3 000 3	127 H 17 X M 1 ZC R 3A	127 H 17 X M 1 ZC R 3A				
HE 807 EN 17 Z 1 A 3 212 3	127 H 17 K M 1 ZC R 3A	127 H 17 X M 1 ZC R 3A	and	HE8C 212	or	HE8C 412
HE 807 EN 17 Z 1 A 3 213 3	127 H 17 S M 1 ZC R 3A	127 H 17 X M 1 ZC R 3A	and	HE8C 213	or	HE8C 413
HE 807 EN 17 Z 1 A 3 117 3	127 H 17 E M 1 ZC R 3AB	127 H 17 X M 1 ZC R 3A	and	HE8C 117	or	HE8C 317
HE 807 FS 17 Z 1 A 3 000 3	127 H 17 XL F 1 Z N 3A	127 H 17 XL F 1 Z N 3A				
HE 807 FS 17 Z 1 A 3 117 3	127 H 17 E F 1 Z N 3A	127 H 17 XL F 1 Z N 3A	and	HE8C 117	or	HE8C 417
HE 807 FS 17 Z 1 A 3 212 3	127 H 17 K F 1 Z N 3AB	127 H 17 XL F 1 Z N 3A	and	HE8C 212	or	HE8C 412
HE 807 FS 17 Z 1 A 3 213 3	127 H 17 S F 1 Z N 3AB	127 H 17 XL F 1 Z N 3A	and	HE8C 213	or	HE8C 413
SYMETRICAL ARRANGEMENTS						
HE 807 FB 17 Y 1 A 6 000 3	127 H 17 XL F 1 YC N 6A	127 H 17 XL F 1 YC N 6A				
HE 807 FB 17 Y 1 A 6 101 3	127 H 17 A F 1 YC N 6A	127 H 17 XL F 1 YC N 6A	and	HE8C 101	or	HE8C 301
HE 807 FB 17 Y 1 A 6 102 3	127 H 17 PA F 1 YC N 6A	127 H 17 XL F 1 YC N 6A	and	HE8C 102	or	HE8C 302
HE 807 FB 17 Y 1 A 6 103 3	127 H 17 D F 1 YC N 6A	127 H 17 XL F 1 YC N 6A	and	HE8C 103	or	HE8C 303
HE 807 EB 17 Y 1 A 6 206 3	127 H 17 IE F 1 YC N 6A	127 H 17 X F 1 YC N 6A	and	HE8C 206	or	HE8C 406
HE 807 EB 17 Y 1 A 6 208 3	127 H 17 KE F 1 YC N 6A	127 H 17 X F 1 YC N 6A	and	HE8C 208	or	HE8C 408
HE 807 EB 17 Y 1 A 6 000 3	127 H 17 X F 1 YC N 6A	127 H 17 X F 1 YC N 6A				
HE 807 FP 17 Y 1 A 6 101 3	127 H 17 A M 1 YC R 6A	127 H 17 XL M 1 YC R 6A	and	HE8C 101	or	HE8C 301
HE 807 FP 17 Y 1 A 6 000 3	127 H 17 XL M 1 YC R 6A	127 H 17 XL M 1 YC R 6A				
HE 807 FP 17 Y 1 A 6 208 3	127 H 17 KE M 1 YC R 6A	127 H 17 X M 1 YC R 6A	and	HE8C 208	or	HE8C 408
HE 807 ES 17 W 0 A 6 000 2	127 H 17 X F 1 W3 N 6A	127 H 17 X F 1 W3 N 6A				
HE 807 FS 17 W 0 A 6 117 2	127 H 17 E F 1 W3 N 6A	127 H 17 XL F 1 W3 N 6A	and	HE8C 117	or	HE8C 317
HE 807 FS 17 W 0 A 6 000 2	127 H 17 XL F 1 W3 N 6A	127 H 17 XL F 1 W3 N 6A				
HE 807 ES 17 W 0 A 6 212 2	127 H 17 K F 1 W3 N 6A	127 H 17 X F 1 W3 N 6A	and	HE8C 212	or	HE8C 412
HE 807 EN 17 W 0 A 6 000 2	127 H 17 X M 1 W3 R 6A	127 H 17 X M 1 W3 R 6A				
HE 807 FN 17 W 0 A 6 117 2	127 H 17 K M 1 W3 R 6A	127 H 17 XL M 1 W3 R 6A	and	HE8C 117	or	HE8C 317
HE 807 FN 17 W 0 A 6 000 2	127 H 17 XL M 1 W3 R 6A	127 H 17 XL M 1 W3 R 6A				
HE 807 EN 17 W 0 A 6 212 2	127 H 17 S M 1 W3 R 6A	127 H 17 X M 1 W3 R 6A	and	HE8C 212	or	HE8C 412
HE 807 ES 17 Y 0 A 6 000 3	127 H 17 X F 1 Y N 6A	127 H 17 X F 1 Y N 6A				
HE 807 FS 17 Y 0 A 6 117 3	127 H 17 E F 1 Y N 6A	127 H 17 XL F 1 Y N 6A	and	HE8C 117	or	HE8C 317
HE 807 FS 17 Y 0 A 6 000 3	127 H 17 XL F 1 Y N 6A	127 H 17 XL F 1 Y N 6A				
HE 807 FS 17 Y 0 A 6 119 3	127 H 17 EF F 1 Y N 6A	127 H 17 XL F 1 Y N 6A	and	HE8C 119	or	HE8C 319
HE 807 ES 17 Y 0 A 6 212 3	127 H 17 K F 1 Y N 6A	127 H 17 X F 1 Y N 6A	and	HE8C 212	or	HE8C 412
HE 807 EN 17 Y 0 A 6 000 3	127 H 17 X M 1 Y R 6A	127 H 17 X M 1 Y R 6A				
HE 807 FN 17 Y 0 A 6 117 3	127 H 17 K M 1 Y R 6A	127 H 17 XL M 1 Y R 6A	and	HE8C 117	or	HE8C 317
HE 807 FN 17 Y 0 A 6 000 3	127 H 17 XL M 1 Y R 6A	127 H 17 XL M 1 Y R 6A				
HE 807 EN 17 Y 0 A 6 212 3	127 H 17 S M 1 Y R 6A	127 H 17 X M 1 Y R 6A	and	HE8C 212	or	HE8C 412
HE 807 ES 17 Z 1 A 6 000 3	127 H 17 X F 1 Z N 6A	127 H 17 X F 1 Z N 6A				
HE 807 FS 17 Z 1 A 6 117 3	127 H 17 E F 1 Z N 6A	127 H 17 XL F 1 Z N 6A	and	HE8C 117	or	HE8C 317
HE 807 FS 17 Z 1 A 6 000 3	127 H 17 XL F 1 Z N 6A	127 H 17 XL F 1 Z N 6A				
HE 807 ES 17 Z 1 A 6 212 3	127 H 17 K F 1 Z N 6A	127 H 17 X F 1 Z N 6A	and	HE8C 212	or	HE8C 412
HE 807 ES 17 Z 1 A 6 213 3	127 H 17 S F 1 Z N 6A	127 H 17 X F 1 Z N 6A	and	HE8C 213	or	HE8C 413
HE 807 EN 17 Z 1 A 6 000 3	127 H 17 X M 1 ZC R 6A	127 H 17 X M 1 ZC R 6A				
HE 807 FN 17 Z 1 A 6 117 3	127 H 17 K M 1 ZC R 6A	127 H 17 XL M 1 ZC R 6A	and	HE8C 117	or	HE8C 317
HE 807 FN 17 Z 1 A 6 000 3	127 H 17 XL M 1 ZC R 6A	127 H 17 XL M 1 ZC R 6A				
HE 807 EN 17 Z 1 A 6 212 3	127 H 17 S M 1 ZC R 6A	127 H 17 X M 1 ZC R 6A	and	HE8C 212	or	HE8C 412
HE 807 EN 17 Z 1 A 6 213 3	127 H 17 S M 1 ZC R 6A	127 H 17 X M 1 ZC R 6A	and	HE8C 213	or	HE8C 413
ES 17-29-41-53 ONLY ON S1						
HE 807 ES 17 S1 1 A 6 000 2	127 H 17 X F 1 X1 N 6A	127 H 17 X F 1 X1 N 6A				
HE 807 FS 17 S1 1 A 6 117 2	127 H 17 E F 1 X1 N 6A	127 H 17 XL F 1 X1 N 6A	and	HE8C 117	or	HE8C 317
HE 807 FS 17 S1 1 A 6 000 2	127 H 17 XL F 1 X1 N 6A	127 H 17 XL F 1 X1 N 6A				
HE 807 ES 17 S1 1 A 6 212 2	127 H 17 K F 1 X1 N 6A	127 H 17 X F 1 X1 N 6A	and	HE8C 212	or	HE8C 412
HE 807 ES 17 S1 1 A 6 213 2	127 H 17 S F 1 X1 N 6A	127 H 17 X F 1 X1 N 6A	and	HE8C 213	or	HE8C 413
ES 17-29-41-53 ONLY ON S2						
HE 807 EN 17 S2 1 A 6 000 2	127 H 17 X M 1 X R 6A	127 H 17 X M 1 X R 6A				
HE 807 FN 17 S2 1 A 6 117 2	127 H 17 K M 1 X R 6A	127 H 17 XL M 1 X R 6A	and	HE8C 117	or	HE8C 317
HE 807 FN 17 S2 1 A 6 000 2	127 H 17 XL M 1 X R 6A	127 H 17 XL M 1 X R 6A				
HE 807 EN 17 S2 1 A 6 212 2	127 H 17 S M 1 X R 6A	127 H 17 X M 1 X R 6A	and	HE8C 212	or	HE8C 412
HE 807 EN 17 S2 1 A 6 213 2	127 H 17 S M 1 X R 6A	127 H 17 X M 1 X R 6A	and	HE8C 213	or	HE8C 413

Cross references chart HE 807 / 127 H

Connectors with 3 fitting locations (72,84,96 and 144 contacts)										
HE 807 references	Amphenol P/N	Amphenol P/N without fitting	and	Brass fittings 2 extremity + 1 central HE8C...	or	Stainless steel fittings 2 extremity + 1 central HE8C...	and	HE8C...	or	HE8C...
ASYMETRICAL ARRANGEMENTS										
HE 807 FB 84 Y 1 A 3 000 3	127 H 84 XL F 1 YC N 3A	127 H 84 XL F 1 YC N 3A								
HE 807 FB 84 Y 1 A 3 101 3	127 H 84 A F 1 YC N 3A	127 H 84 XL F 1 YC N 3A	and	HE8C 101	and	HE8C 102	or	HE8C 301	and	HE8C 302
HE 807 FB 84 Y 1 A 3 102 3	127 H 84 PA F 1 YC N 3A	127 H 84 XL F 1 YC N 3A	and	HE8C 102	and	HE8C 102	or	HE8C 302	and	HE8C 302
HE 807 FB 84 Y 1 A 3 103 3	127 H 84 D F 1 YC N 3A	127 H 84 XL F 1 YC N 3A	and	HE8C 103	and	HE8C 102	or	HE8C 303	and	HE8C 302
HE 807 FB 84 Y 1 A 3 206 3	127 H 84 IE F 1 YC N 3AB	127 H 84 XL F 1 YC N 3AB	and	HE8C 206	and	HE8C 206	or	HE8C 406	and	HE8C 406
HE 807 FB 84 Y 1 A 3 208 3	127 H 84 KE F 1 YC N 3AB	127 H 84 XL F 1 YC N 3AB	and	HE8C 208	and	HE8C 208	or	HE8C 408	and	HE8C 408
HE 807 EP 84 Y 1 A 3 000 3	127 H 84 X M 1 YC R 3A	127 H 84 X M 1 YC R 3A								
HE 807 EP 84 Y 1 A 3 101 3	127 H 84 A M 1 YC R 3AB	127 H 84 X M 1 YC R 3A	and	HE8C 101	and	HE8C 102	or	HE8C 301	and	HE8C 302
HE 807 FS 84 W 1 B 3 000 2	127 H 84 XL F 1 W3 N 3A	127 H 84 XL F 1 W3 N 3A								
HE 807 FS 84 W 1 B 3 212 2	127 H 84 K F 1 W3 N 3AB	127 H 84 XL F 1 W3 N 3A	and	HE8C 212	and	HE8C 229	or	HE8C 412	and	HE8C 429
HE 807 EN 84 W 0 B 3 000 2	127 H 84 X M 1 W3 R 3A	127 H 84 X M 1 W3 R 3A								
HE 807 EN 84 W 0 B 3 212 2	127 H 84 K M 1 W3 R 3AB	127 H 84 X M 1 W3 R 3A	and	HE8C 212	and	HE8C 229	or	HE8C 412	and	HE8C 429
HE 807 EN 84 W 0 B 3 117 2	127 H 84 E M 1 W3 R 3AB	127 H 84 X M 1 W3 R 3A	and	HE8C 117	and	HE8C 129	or	HE8C 317	and	HE8C 329
HE 807 EN 84 Y 0 A 3 000 3	127 H 84 X M 1 Y R 3A	127 H 84 X M 1 Y R 3A								
HE 807 EN 84 Y 0 A 3 212 3	127 H 84 K M 1 Y R 3AB	127 H 84 X M 1 Y R 3A	and	HE8C 212	and	HE8C 229	or	HE8C 412	and	HE8C 429
HE 807 EN 84 Y 0 A 3 117 3	127 H 84 E M 1 Y R 3AB	127 H 84 X M 1 Y R 3A	and	HE8C 117	and	HE8C 129	or	HE8C 317	and	HE8C 329
HE 807 FS 84 Y 0 A 3 000 3	127 H 84 XL F 1 Y N 3A	127 H 84 XL F 1 Y N 3A								
HE 807 FS 84 Y 0 A 3 212 3	127 H 84 K F 1 Y N 3AB	127 H 84 XL F 1 Y N 3A	and	HE8C 212	and	HE8C 229	or	HE8C 412	and	HE8C 429
HE 807 EN 84 Z 1 B 3 000 3	127 H 84 X M 1 ZC R 3A	127 H 84 X M 1 ZC R 3A								
HE 807 EN 84 Z 1 B 3 212 3	127 H 84 K M 1 ZC R 3AB	127 H 84 X M 1 ZC R 3A	and	HE8C 212	and	HE8C 229	or	HE8C 412	and	HE8C 429
HE 807 EN 84 Z 1 B 3 119 3	127 H 84 EF M 1 ZC R 3AB	127 H 84 X M 1 ZC R 3A	and	HE8C 119	and	HE8C 129	or	HE8C 319	and	HE8C 329
HE 807 FS 84 Z 1 B 3 000 3	127 H 84 XL F 1 Z N 3A	127 H 84 XL F 1 Z N 3A								
HE 807 FS 84 Z 1 B 3 212 3	127 H 84 K F 1 Z N 3AB	127 H 84 XL F 1 Z N 3A	and	HE8C 212	and	HE8C 229	or	HE8C 412	and	HE8C 429
SYMETRICAL ARRANGEMENTS										
HE 807 FB 56 Y 1 A 10 000 3	127 H 56 XL F 1 YC N 10A	127 H 56 XL F 1 YC N 10A								
HE 807 FB 56 Y 1 A 10 101 3	127 H 56 A F 1 YC N 10A	127 H 56 XL F 1 YC N 10A	and	HE8C 101	and	HE8C 102	or	HE8C 301	and	HE8C 302
HE 807 FP 56 Y 1 A 10 000 3	127 H 56 XL M 1 YC R 10A	127 H 56 XL M 1 YC R 10A								
HE 807 FP 56 Y 1 A 10 101 3	127 H 56 X M 1 YC R 10A	127 H 56 XL M 1 YC R 10A	and	HE8C 101	and	HE8C 102	or	HE8C 301	and	HE8C 302
HE 807 ES 56 W 0 B 10 000 2	127 H 56 X F 1 W3 N 10A	127 H 56 X F 1 W3 N 10A								
HE 807 ES 56 W 0 B 10 212 2	127 H 56 K F 1 W3 N 10A	127 H 56 X F 1 W3 N 10A	and	HE8C 212	and	HE8C 229	or	HE8C 412	and	HE8C 429
HE 807 EN 56 W 0 B 10 000 2	127 H 56 X M 1 W3 R 10A	127 H 56 X M 1 W3 R 10A								
HE 807 FN 56 W 0 B 10 000 2	127 H 56 XL M 1 W3 R 10A	127 H 56 XL M 1 W3 R 10A								
HE 807 ES 56 Y 0 A 10 000 3	127 H 56 X F 1 Y N 10A	127 H 56 X F 1 Y N 10A								
HE 807 FS 56 Y 0 A 10 117 3	127 H 56 E F 1 Y N 10A	127 H 56 XL F 1 Y N 10A	and	HE8C 117	and	HE8C 129	or	HE8C 317	and	HE8C 329
HE 807 ES 56 Y 0 A 10 212 3	127 H 56 K F 1 Y N 10A	127 H 56 X F 1 Y N 10A	and	HE8C 212	and	HE8C 229	or	HE8C 412	and	HE8C 429
HE 807 EN 56 Y 0 A 10 000 3	127 H 56 X M 1 Y R 10A	127 H 56 X M 1 Y R 10A								
HE 807 EN 56 Y 0 A 10 212 3	127 H 56 K M 1 Y R 10A	127 H 56 X M 1 Y R 10A	and	HE8C 212	and	HE8C 229	or	HE8C 412	and	HE8C 429
HE 807 ES 56 Z 1 B 10 000 3	127 H 56 X F 1 Z N 10A	127 H 56 X F 1 Z N 10A								
HE 807 ES 56 Z 1 B 10 213 3	127 H 56 S F 1 Z N 10A	127 H 56 X F 1 Z N 10A	and	HE8C 213	and	HE8C 229	or	HE8C 413	and	HE8C 429
HE 807 EN 56 Z 1 B 10 000 3	127 H 56 X M 1 ZC R 10A	127 H 56 M 1 ZC R 10A								
HE 807 FN 56 Z 1 B 10 000 3	127 H 56 XL M 1 ZC R 10A	127 H 56 XL M 1 ZC R 10A								
72 + 6A ONLY ON S1										
HE 807 ES 72 S11 A 6 000 2	127 H 72 X F 1 X1 N 6A	127 H 72 X F 1 X1 N 6A								
HE 807 FS 72 S11 A 6 000 2	127 H 72 XL F 1 X1 N 6A	127 H 72 XL F 1 X1 N 6A								
72 + 6A ONLY ON S2										
HE 807 EN 72 S21 A 6 000 2	127 H 72 X M 1 X R 6A	127 H 72 X M 1 X R 6A								
HE 807 FN 72 S21 A 6 000 2	127 H 72 XL M 1 X R 6A	127 H 72 XL M 1 X R 6A								

Table of contents

DESCRIPTION & CHARACTERISTICS	1
ARRANGEMENTS	2
CONTACTS & FITTINGS	3
TOOLING	3
FITTINGS	
Plugs – Male fittings	4
Receptacles – Female fittings	5
CONTACTS FOR HE 807 / 127 H CONNECTORS	
Power contacts	6
Coaxial contacts	7
Optical termini	8
PANEL & PCB DRILLING	
For HE 801- HE 804 / 127 connectors	9
For HE 807 / 127 H connectors	10
ACCESSORIES FOR HE 804 PLUGS	
Hoods for HE 804 plugs	12
Locking systems for HE 804 plugs	13
CONNECTORS ORDERING INFORMATION	
HE 801 – HE 804 3-row female plugs	15
HE 801 – HE 804 3-row male receptacles	15
HE 801 – HE 804 2-row female plugs	16
HE 801 – HE 804 2-row male receptacles	16
HE 801 – HE 804 2-row male plugs	17
HE 801 – HE 804 2-row female receptacles	17
HE 807 male or female plugs	18
HE 807 male or female receptacles	19
Fittings	19
CROSS REFERENCES	
HE 801 / 127	20
HE 804 / 127	21
HE 807 / 127 H	22

Do not hesitate to contact us for further information



Amphenol

Amphenol Socapex
Mil/Aero & Industrial Business Unit

948, Promenade de l'Arve - BP 29
 F - 74311 Thyez Cedex

Tel.: +33 (0) 4 50 89 28 00 - Fax: +33 (0) 4 50 96 19 41
<http://www.amphenol.com>

Sales office in Paris

Tel.: +33 (0) 1 49 05 30 00 - Fax: +33 (0) 1 49 05 30 43