

PRODUCT NUMBER

77311-YXX-XXLF

PLATING SEE SHEET 2

PIN STYLE SEE SHEET 2

WHEN REQUIRED, ADD SUFFIX LETTER "LF"
INDICATES THE PRODUCT IS RoHS
COMPATIBLE, SEE NOTE 6
TOTAL NB OF POSITIONS 01 TO 36
OPTION LETTER SEE NOTE 7

PRODUCT NUMBER (BERGSTRIK PACKAGING)

77311-YXX-00LF

PLATING

1= 0.76µm GOLD/GXT ON CONTACT
AREA, 2µm TIN MIN ON TAILS

8= 0.38µm GOLD/GXT ON CONTACT
AREA, 2µm TIN MIN ON TAILS

4= 2.0µm TIN MIN FULL PLATED

1.27µm NICKEL MIN UNDERLAYER FOR
ALL PLATING VERSIONS

INDICATES THE PRODUCT IS RoHS
COMPATIBLE, SEE NOTE 6

POSITIONS PER REEL : 00=36,000 (BERGSTRIK)

PIN STYLE	MATING	SOLDER	OAL
01	5.84	2.41	10.8
02	5.84	3.42	11.8
18	5.84	3.05	11.43
22	7.75	3.05	13.35
24	6.75	2.9	12.2
27	6.6	2.66	11.8

NOTES:

- HOUSING MAT'L : HIGH TEMPERATURE THERMOPLASTIC. UL94V-0 COLOR: BLACK
- PIN MATERIAL : PHOSPHOR BRONZE
- BERGSTIK PRODUCT PACKAGED IN POLY BAGS. BERGSTRIK PRODUCT PACKAGED PER REELS.
- 9N MIN RETENTION IN EITHER DIRECTION

5. TO DETERMINE DIMENSIONS :

N = NUMBER OF POSITIONS PER ROW
EXAMPLE : 8 POS N x 2.54 = 20.32mm

6. RoHS COMPATIBLE PRODUCT SPECIFICATIONS

a - PLATING:

- "LF" MEANS THE PRODUCT IS LEAD-FREE, 2µm MINIMUM MATTE TIN OVER 1.27µm MINIMUM NICKEL UNDERPLATE.

b - MANUFACTURING PROCESS COMPATIBILITY

- THE HOUSING WILL WITHSTAND EXPOSURE TO 260°C ±5°C SOLDER BATH TEMPERATURE FOR 5 SECONDS IN A WAVE SOLDER APPLICATION WITH A 1.6mm MIN THICK CIRCUIT BOARD.

c - LABELING:

- MEETS PACKAGING SPECS AS PER GS-14-920

d - LEGAL STATEMENT: SEE GS-22-008

7. OPTION LETTER :

T = TUBE PACKAGING WITHOUT PICK UP CAP

K = TAPE & REEL PACKAGING, WITHOUT PICK UP CAP ONLY FOR P/N 77311-462K04(LF) AND 77311-462K05(LF)

C = HIGHT RETENTION FEATURES, SEE SHEET 2

R = RETENTION FEATURES, SEE SHEET 2
IF RETENTION FEATURE "R" AND TUBE PACKAGING "T" ARE BOTH REQUIRED
OPTIONAL LETTER "R" WILL APPEAR INSTEAD OF THE FIRST DASH
EXAMPLE : 77311R424T03LF

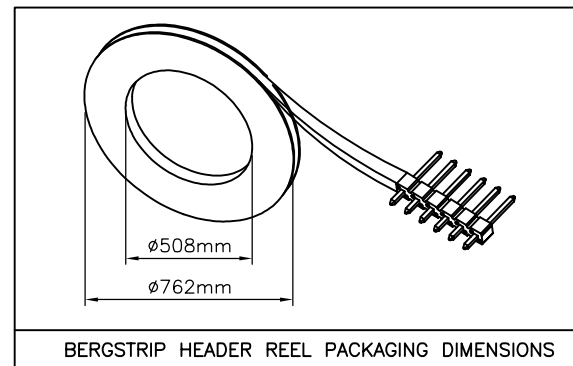
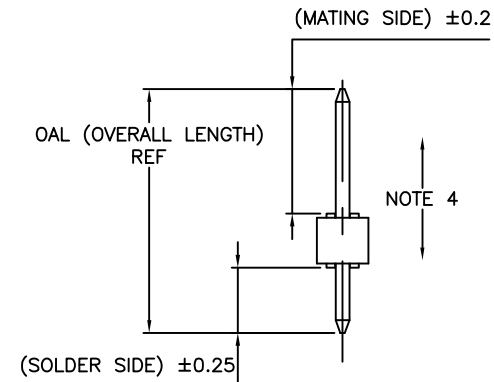
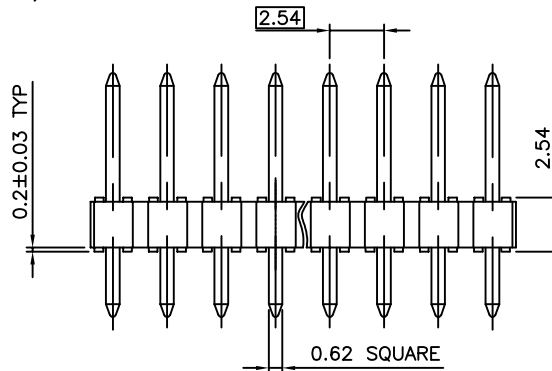
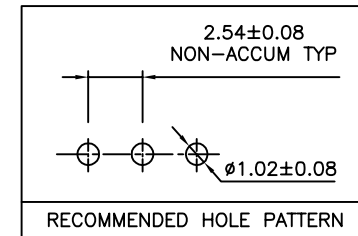
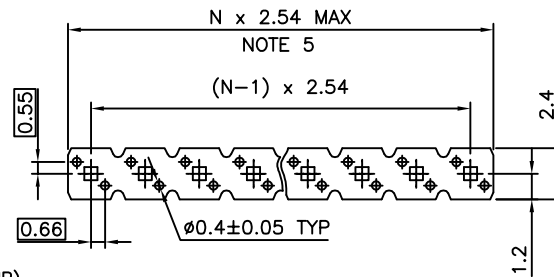

mat'l. code SEE NOTES		surface ISO 1302	tolerance ISO 406 ISO 1101	projection	product family BERGSTIK
ltr	ecn no	dr	date	tolerances unless otherwise specified	title
BG	F08-0148	RTR	08.03.31	angles	UNSHR.HEADER STR SR TMT
BH	F08-0250	LMU	08.12.16	linear	
BJ	F09-0078	LMU	09.08.24	.x ±0.3	mm
BK	F09-0095	JCO	09.11.02	.xx ±0.15	scale 5:1
BL	F10-0091	LMU	11.05.23	.xxx ±0.05	dwg no
BM	F11-0074	JCO	11.06.20		sheet 1 of 2
BN	F11-0307	LMU	11.09.26		size
sheet	revision	BN	BF		77311
index	sheet	1	2		A3
					type
					CUSTOMER
					Drawing

RETENTION FEATURES

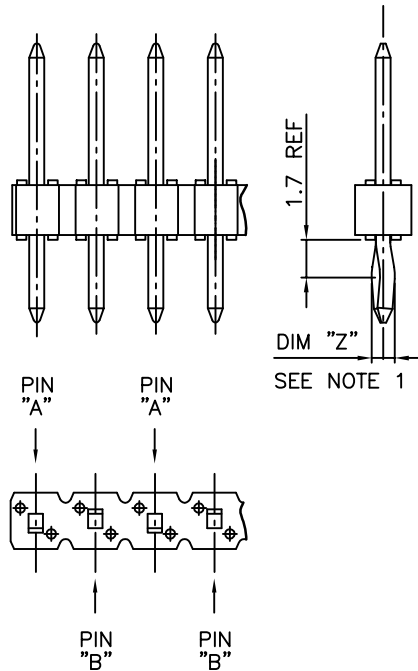

CORE RANGE				
PLATING	PIN STYLE	MATING	SOLDER	OAL
1	01	5.84	2.41	10.8
1	18	5.84	3.05	11.43

PLATING
 1 = 0.76µm GOLD/GXT ON CONTACT AREA
 3.81µm TIN/LEAD ON TAIL

- WHEN "LF" IS REQUIRED, 2µm MATTE TIN OVER 1.27µm MIN NICKEL IS PROVIDED INSTEAD OF TIN-LEAD

CATALOGUE RANGE				
PLATING	PIN STYLE	MATING	SOLDER	OAL
4/8	01	5.84	2.41	10.8
1/4/8	02	5.84	3.42	11.8
4/8	18	5.84	3.05	11.43
1/4/8	22	7.75	3.05	13.35
1/4/8	24	6.75	2.9	12.2
1/4/8	27	6.6	2.65	11.8

APPLICATION SPECIFIC				
PLATING	PIN STYLE	MATING	SOLDER	OAL
1/4/8	03	5.72	5.09	13.35
1/4/8	05	5.72	10.14	18.4
1/4/8	15	8.51	2.55	13.6
1/4/8	19	12.83	3.03	18.4
1/4/8	20	15.37	3.04	20.95
1/4/8	26	15.57	2.84	20.95
1/4/8	29	17.5	3.46	23.5
1/4/8	32	10.3	3.05	15.9
1/4/8	38	5.84	3.82	12.2
1/4/8	46	8.08	2.98	13.6
1/4/8	58	14.47	3.05	20.06
1/4/8	62	13.5	3.05	19.09
1/4/8	70	6.54	3.50	12.57
1/4/8	83	20.46	3.00	26.00
1/4/8	85	5.72	8.51	16.76
1/4/8	87	6.98	3.05	12.57
1/4/8	91	5.6	10.21	18.35
1/4/8	92	5.65	12.76	20.95
1/4/8	93	6.00	4.81	13.35
1/4/8	94	15.60	3.20	21.25
1/4/8	95	10.00	8.45	20.95
1/4/8	96	10.95	3.05	16.55
1/4/8	97	9.00	3.55	15.09
1/4/8	98	3.00	1.35	6.84
1/4/8	99	24.00	3.05	29.50

NOTE 6

RETENTION FEATURES :

- 1 - PART NUMBER 77311-XXXXXXLF: DIM "Z"=(0.99)
PART NUMBER 77311-XXXXXXLF: DIM "Z"= 1.05MIN -1.15MAX
- 2 - PINS "A" AND "B" USED FOR RETENTION.
- 3 - DIRECTION OF RETENTION SHOWN BY ARROWS.
- 4 - ON 4 TO 36 POSITIONS HEADER; RETENTION IS IN MID POSITION OF HEADER (4 CENTRAL PINS)
- 5 - FOR RETENTION OPTION , SOLDER TAIL LENGTH TO BE 2.9 MIN UP TO 3.5 MAX.

PLATING SPECIFICATIONS :

- 6 - 8.0MM GOLD / GXT PLATING AREA FROM PIN TIP ON MATING SIDE

PLATING

- 1 = 0.76µm GOLD/GXT ON CONTACT AREA 3.81µm TIN-LEAD ON TAIL
- 4 = 3.81µm TIN-LEAD ON CONTACT AREA 3.81µm TIN-LEAD ON TAIL
- 8 = 0.38µm GOLD/GXT ON CONTACT AREA 3.81µm TIN-LEAD ON TAIL

- WHEN "LF" IS REQUIRED, 2µm MATTE TIN OVER 1.27µm MIN NICKEL PROVIDED INSTEAD OF TIN-LEAD

mat'l. code		surface <input checked="" type="checkbox"/> ISO 1302		tolerance <input checked="" type="checkbox"/> ISO 406 <input type="checkbox"/> ISO 1101		projection		product family BERGSTIK		
ltr	ecn no	dr	date	tolerances unless otherwise specified				title UNSHR.HEADER STR SR TMT		
BD	F10-009	LMU	11.05.23	angles	linear	scale N/A		dwg no 77311 sheet 2 of - size A3		
BE	F11-0074	JCO	11.06.20					type CUSTOMER Drawing		
BF	F11-0307	LMU	11.09.26							
		dr	D.LE	01.01.24						
BA	F08-0250	LMU	08.12.16	enrg	JM.C	01.01.24				
BB	F09-0078	LMU	09.08.24	chr	JM.C	01.01.24				
BC	F09-0095	LMU	09.09.17	appd	JF.N	01.01.24				
sheet index	revision sheet									