

LOC		DIST		P		ZONE		LTR		REVISIONS		DATE	APPD
DW	00									AN	REVISED PER EC 0513-0432-03	05JAN04	JG

1 MATERIALS:
 HOUSING- PPA RESIN, BLACK,
 MOLDING COMPOUND.
 CONTACTS- PHOSPHOR BRONZE PLATED WITH
 MINIMUM THICK (SEE TABLE) GOLD IN CONTACT
 AREA AND 3.8µm [.000150] MINIMUM THICK
 TIN-LEAD ON SOLDER TINES OVER 1.27µm
 [.000050] MINIMUM THICK NICKEL UNDERPLATE.
 RETENTION LEG- BRASS PLATED WITH 3.8µm
 [.000150] MINIMUM TIN-LEAD OVER 1.3µm
 [.000051] MINIMUM NICKEL UNDERPLATE.

- 2 G, J, AND H INDICATE NUMBER OF POSITION MARKED ON ASSEMBLY. ALSO SEE TABLE.
- 3 ALL DIMENSIONS SHOWN ARE MAXIMUM UNLESS OTHERWISE SPECIFIED.
- 4. 60 POSITION AS SHOWN.
- 5 RETENTION LEGS NOT PRESENT.
- 6 TOP OF RETENTION LEG MAY NOT PROTRUDE ABOVE THIS SURFACE.
- 7 HOUSING BOW UP TO 0.30 [.012] ALLOWED.
- 8 CONNECTOR WILL ACCOMMODATE MATING PRINTED CIRCUIT BOARD OF 1.6±0.07 [.063±.003] THICKNESS.
- 9 PRELIMINARY - NOT RELEASED FOR PRODUCTION.

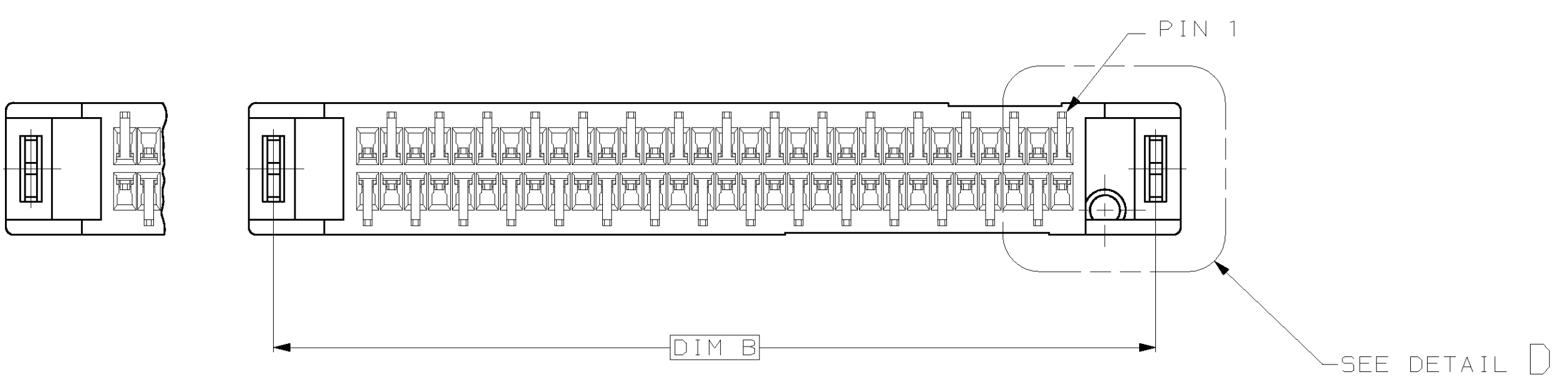
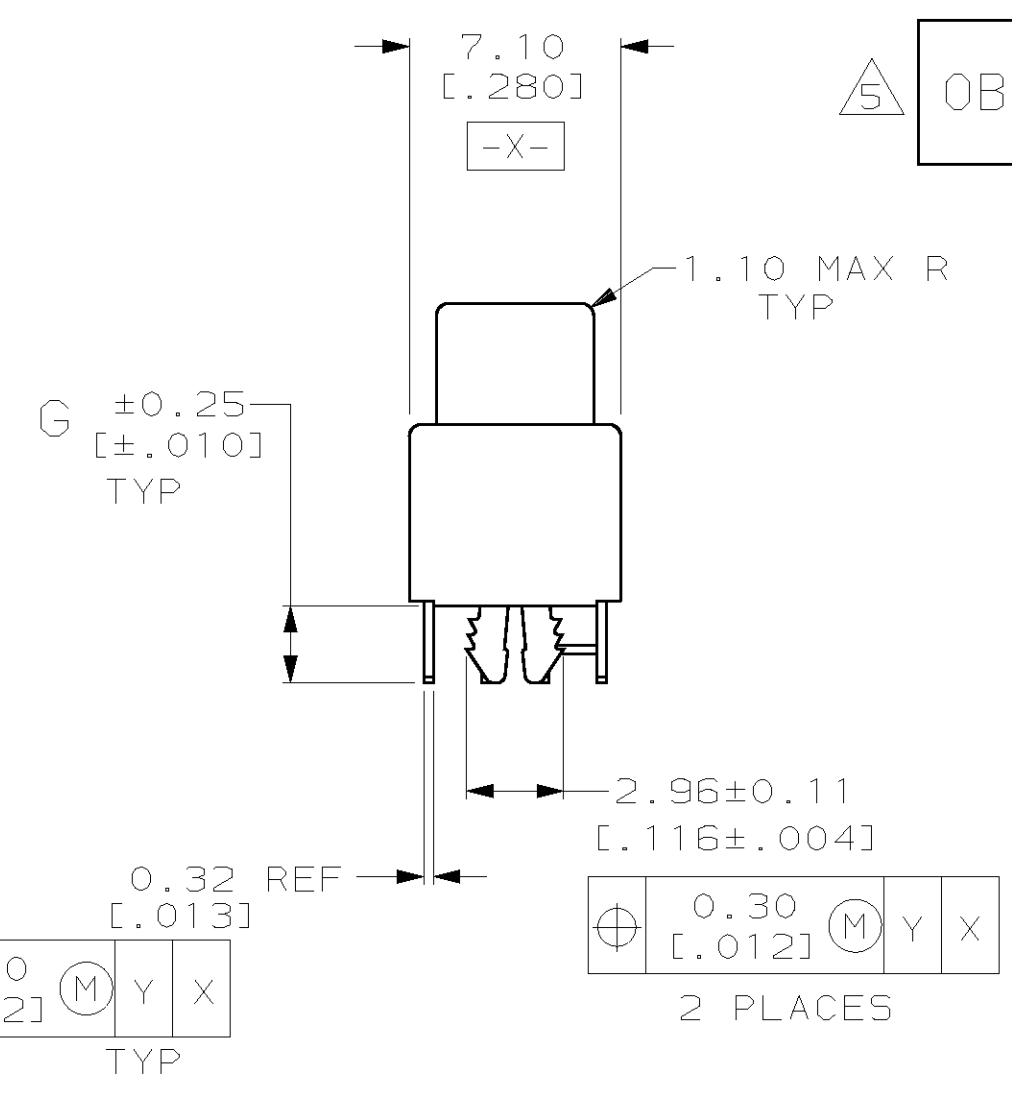
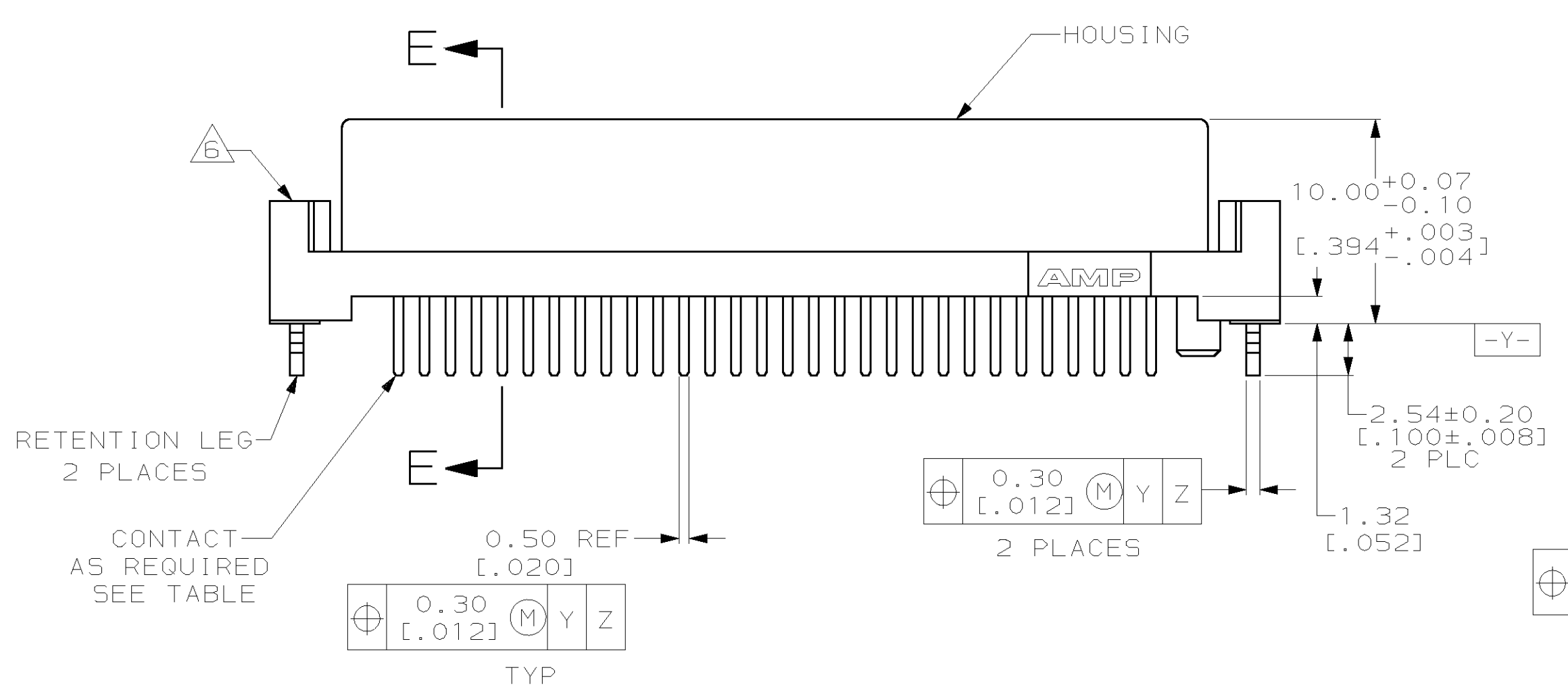
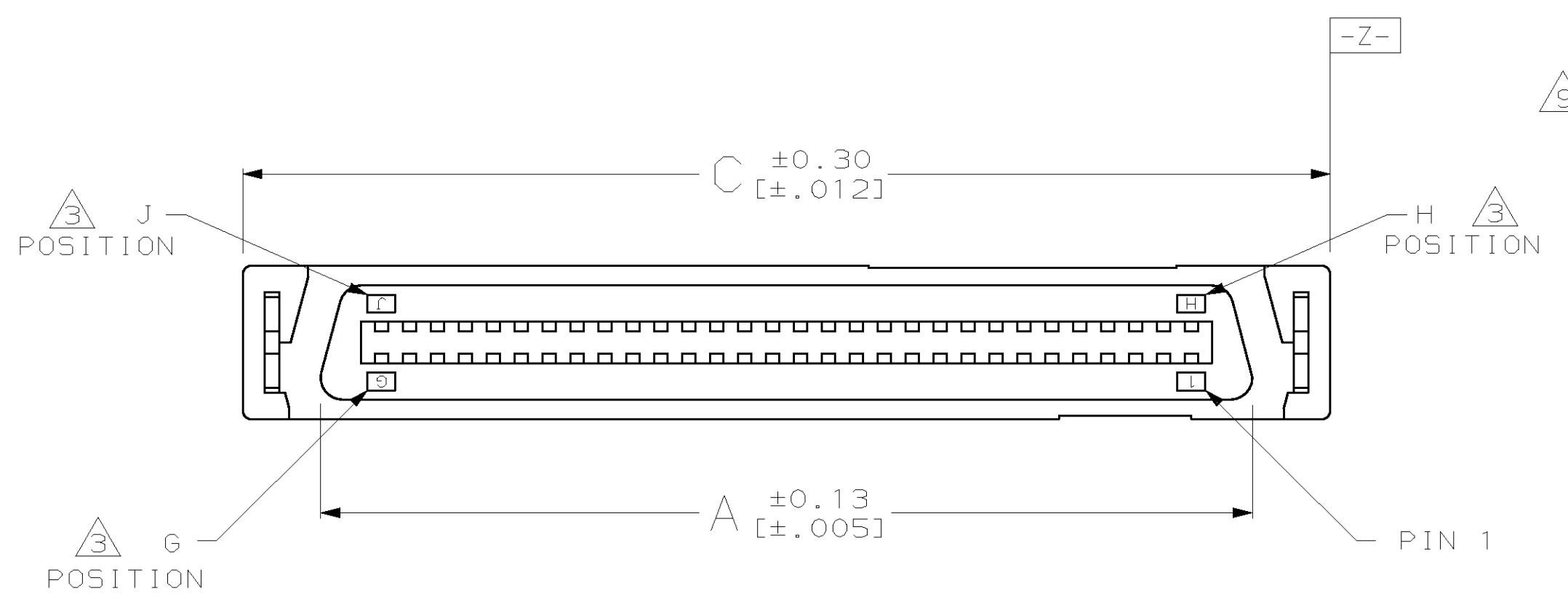
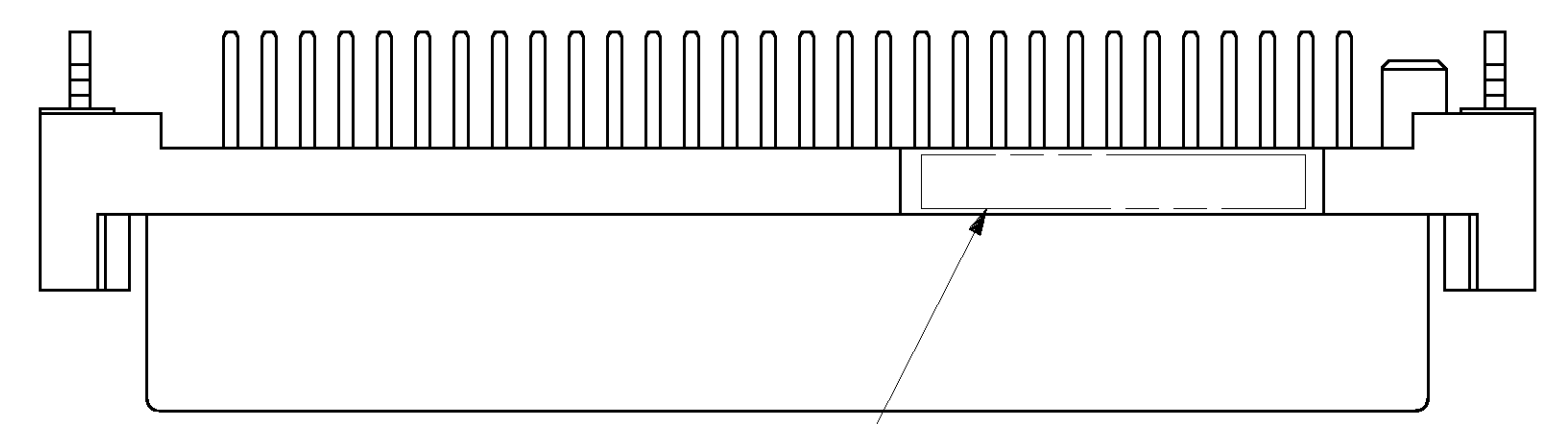

2.36 [.093]	3.40 [.134]	38.53 [1.517]	49.45 [1.947]	46.81 [1.843]	42.37 [1.668]	30	60	31	0.00076 [.000030]	60	5-557103-2
2.36 [.093]	2.54 [.100]	43.61 [1.717]	54.53 [2.147]	51.89 [2.043]	47.45 [1.868]	34	68	35	0.00076 [.000030]	68	5-557103-1
2.36 [.093]	3.30 [.130]	32.18 [1.267]	43.10 [1.697]	40.46 [1.593]	36.02 [1.418]	25	50	26	0.00076 [.000030]	50	5-577103-0
2.36 [.093]	3.30 [.130]	76.63 [3.017]	87.55 [3.447]	84.91 [3.343]	80.47 [3.168]	60	120	61	0.00076 [.000030]	120	4-557103-9
2.36 [.093]	3.30 [.130]	127.43 [5.017]	138.35 [5.447]	135.71 [5.343]	131.27 [5.168]	100	200	101	0.00076 [.000030]	200	4-557103-2
0.8-1.6 [.031-.063]	2.54 [.100]	127.43 [5.017]	138.35 [5.447]	135.71 [5.343]	131.27 [5.168]	100	200	101	0.00076 [.000030]	200	4-557103-1
0.8-1.6 [.031-.063]	2.54 [.100]	102.03 [4.017]	112.95 [4.447]	110.31 [4.343]	105.87 [4.168]	80	160	81	0.00076 [.000030]	160	3-557103-7
0.8-1.6 [.031-.063]	2.54 [.100]	82.98 [3.267]	93.90 [3.697]	91.26 [3.593]	86.82 [3.418]	65	130	66	0.00076 [.000030]	130	3-557103-3
0.8-1.6 [.031-.063]	2.54 [.100]	76.63 [3.017]	87.55 [3.447]	84.91 [3.343]	80.47 [3.168]	60	120	61	0.00076 [.000030]	120	2-557103-9
2.36 [.093]	3.30 [.130]	63.93 [2.517]	74.85 [2.947]	72.21 [2.843]	67.77 [2.668]	50	100	51	0.00076 [.000030]	100	2-557103-7
0.8-1.6 [.031-.063]	2.54 [.100]	63.93 [2.517]	74.85 [2.947]	72.21 [2.843]	67.77 [2.668]	50	100	51	0.00076 [.000030]	100	2-557103-6
0.8-1.6 [.031-.063]	2.54 [.100]	63.93 [2.517]	74.85 [2.947]	72.21 [2.843]	67.77 [2.668]	50	100	51	0.00076 [.000030]	100	2-557103-5
2.36 [.093]	3.30 [.130]	51.23 [2.017]	62.15 [2.447]	59.51 [2.343]	55.07 [2.168]	40	80	41	0.00076 [.000030]	80	2-557103-3
0.8-1.6 [.031-.063]	2.54 [.100]	51.23 [2.017]	62.15 [2.447]	59.51 [2.343]	55.07 [2.168]	40	80	41	0.00076 [.000030]	80	2-557103-2
0.8-1.6 [.031-.063]	2.54 [.100]	51.23 [2.017]	62.15 [2.447]	59.51 [2.343]	55.07 [2.168]	40	80	41	0.00076 [.000030]	80	2-557103-1
0.8-1.6 [.031-.063]	2.54 [.100]	43.61 [1.717]	54.53 [2.147]	51.89 [2.043]	47.45 [1.868]	34	68	35	0.00076 [.000030]	68	1-557103-7
0.8-1.6 [.031-.063]	2.54 [.100]	43.61 [1.717]	54.53 [2.147]	51.89 [2.043]	47.45 [1.868]	34	68	35	0.00076 [.000030]	68	1-557103-3
0.8-1.6 [.031-.063]	2.54 [.100]	32.18 [1.267]	43.10 [1.697]	40.46 [1.593]	36.02 [1.418]	25	50	26	0.00076 [.000030]	50	557103-9
0.8-1.6 [.031-.063]	2.54 [.100]	25.83 [1.017]	36.75 [1.447]	34.11 [1.343]	29.67 [1.168]	20	40	21	0.00076 [.000030]	40	557103-5
0.8-1.6 [.031-.063]	2.54 [.100]	-	30.40 [1.197]	27.96 [1.101]	23.32 [.918]	15	30	16	0.00076 [.000030]	30	557103-1
PCB THICKNESS	G	F	C	B	A	G	J	H	GOLD	POSN	PART NO

9 SUPERSEDED BY 3-786925-3

5 OBSOLETE

DO NOT SCALE PRINT.
 UNLESS SPECIFIED
 DIMENSIONS IN mm [INCHES]
 TOLERANCES ON:
 2 PLC DEC ±
 3 PLC DEC ±
 ANGLES ±

DR 8-25-89
 A.HOLT
 CHK 10-3-89
 N.JONES
 APPD 12-4-89
 T.PIZZULO
 APPD 12-4-89
 J.B.WILKERSON
 PRODUCT SPEC
 108-1367
 APPLICATION SPEC
 114-6045
 WEIGHT

AMP INCORPORATED
 Harrisburg, Pa. 17105
 NAME
 RECEPTACLE ASSEMBLY, VERTICAL
 BOARD TO BOARD, CHAMPTM 050,
 SERIES I
 SIZE D
 CAGE CODE 00779
 DRAWING NO. 557103-2
 SCALE 4:1

SUPERSEDED
NOT THE LATEST REVISION

LOC		DIST		P		F		ZONE		LTR		REVISIONS		DATE	APPD
DW	00												AN	SEE SHEET 1	

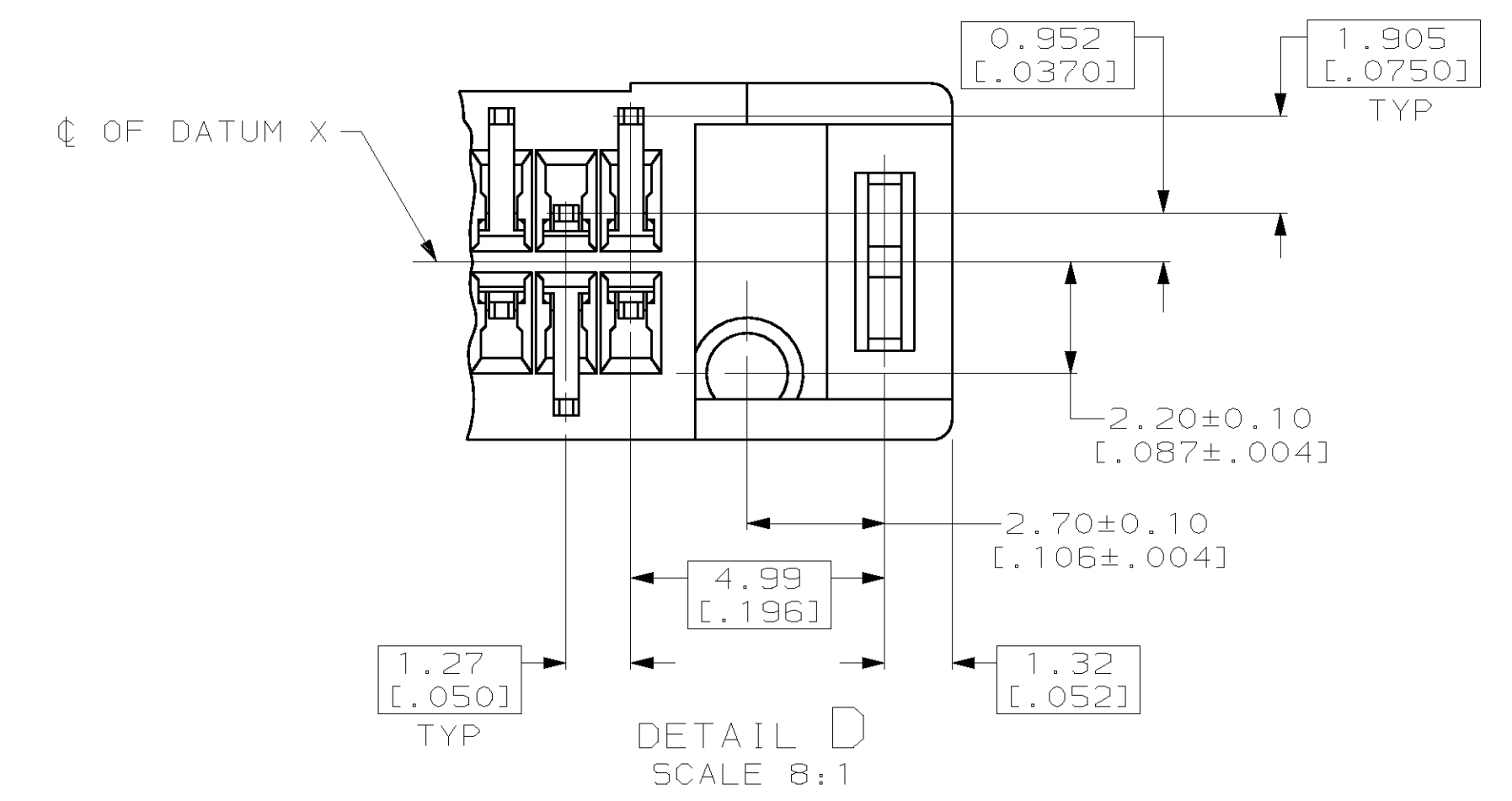
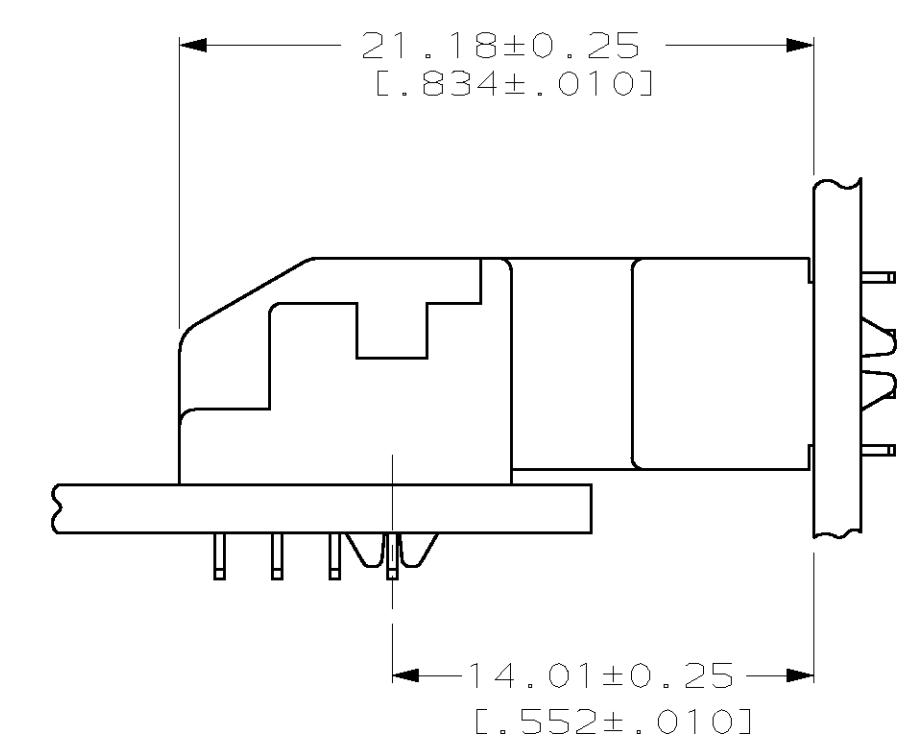
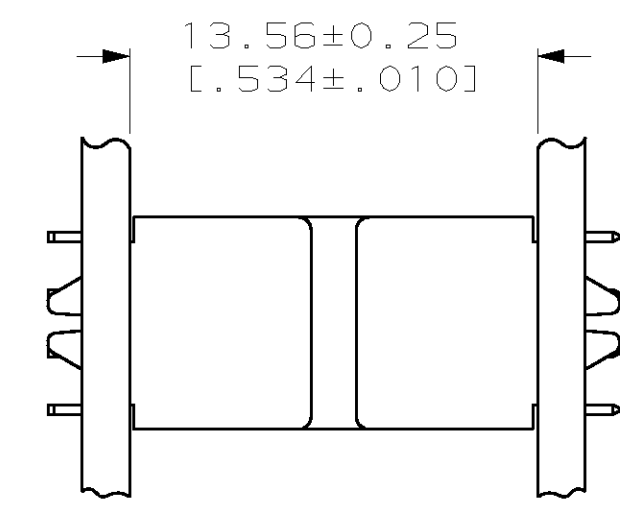
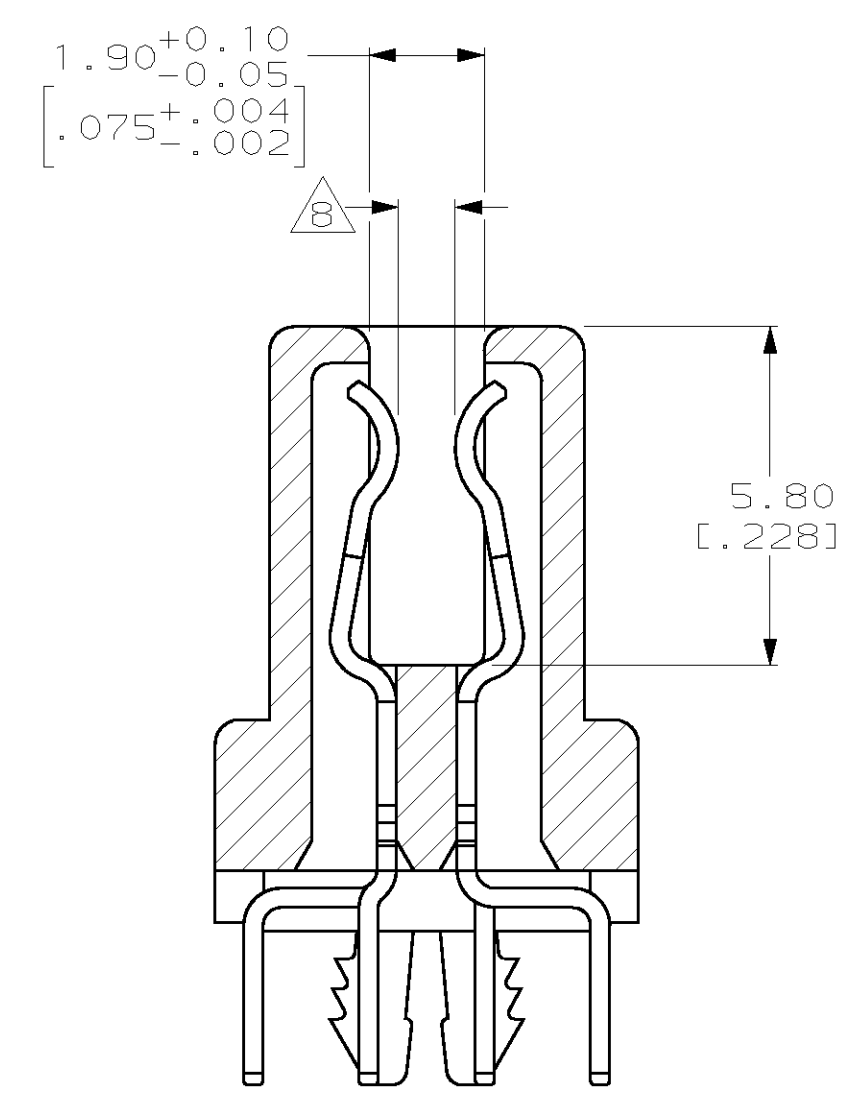
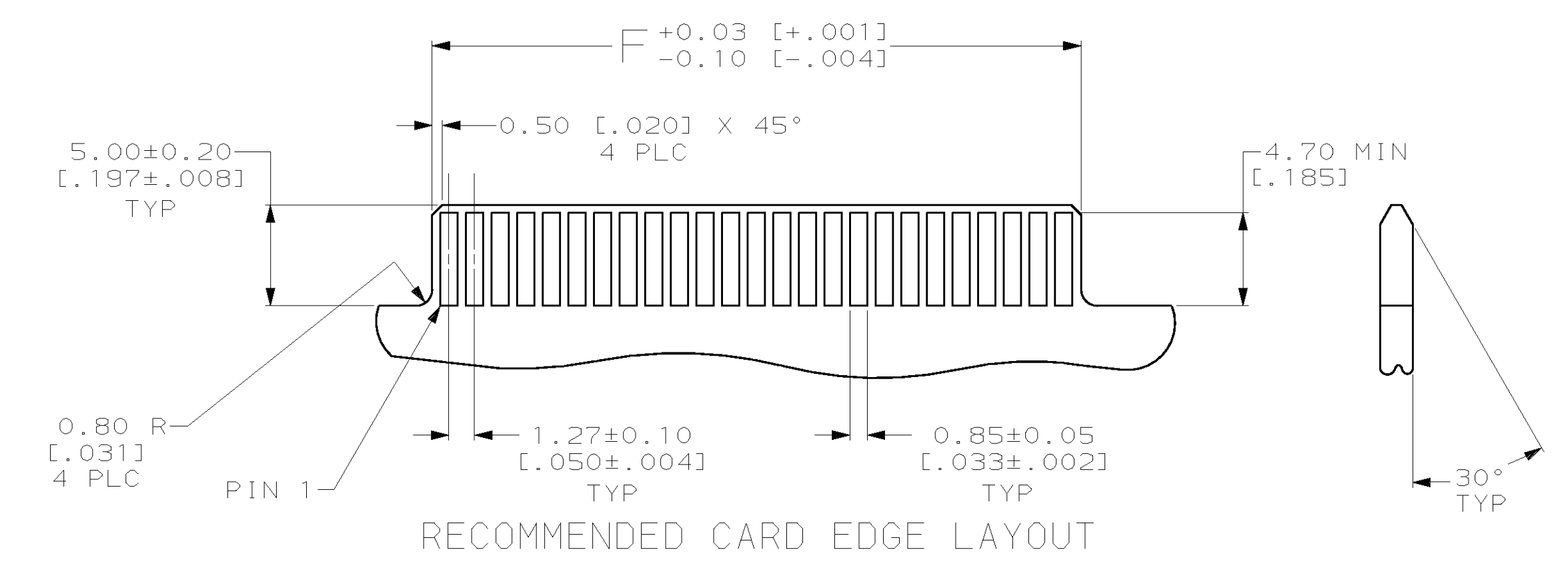
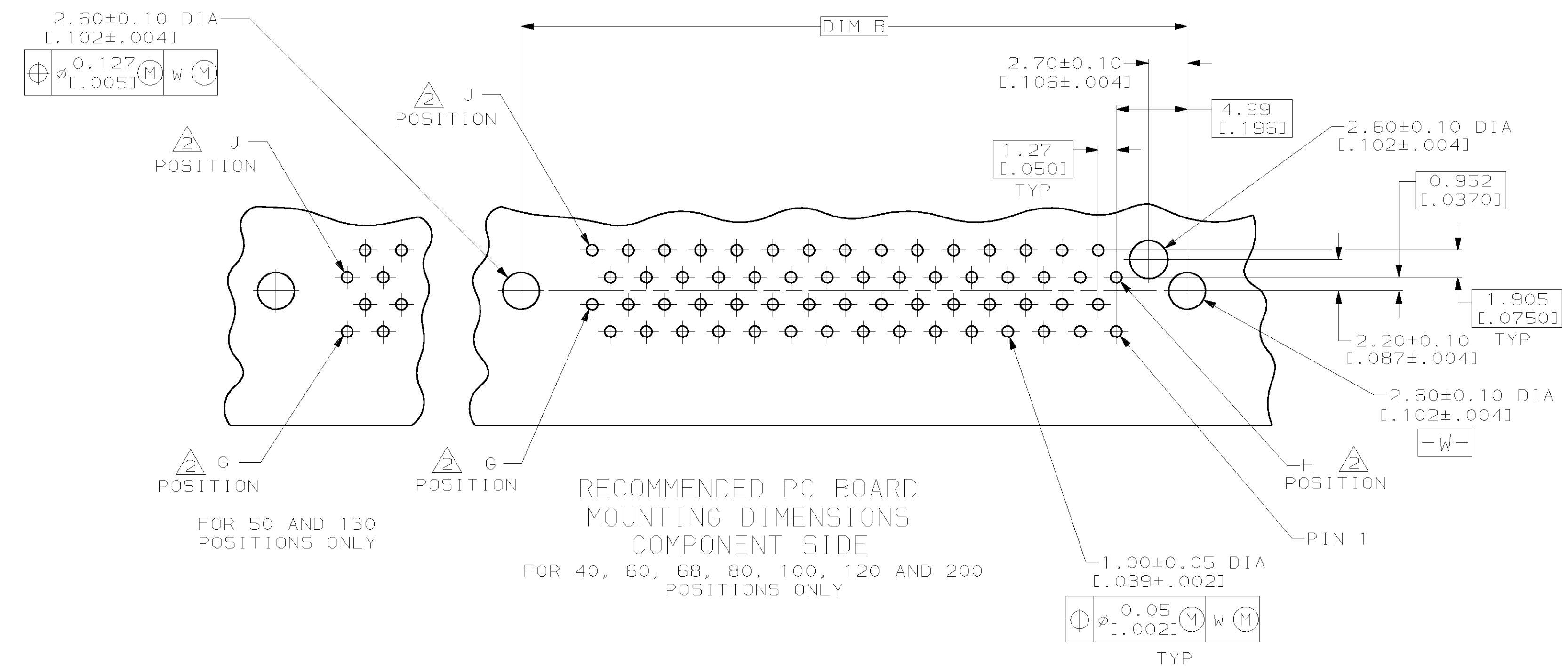

DO NOT SCALE PRINT. UNLESS SPECIFIED DIMENSIONS IN mm [INCHES]		DR 8-25-89 A.HOLT		PART NO	
TOLERANCES ON:		CHK 10-3-89 N.JONES		AMP INCORPORATED Harrisburg, Pa. 17105	
2 PLC DEC ± -		APPD 12-4-89 T.PIZZULO			
3 PLC DEC ± -		APPD 12-4-89 J.B.WILKERSON			
ANGLES ± -		MATERIAL	PRODUCT SPEC	NAME	
				RECEPTACLE ASSEMBLY, VERTICAL, BOARD-TOBOARD, CHAMP™ .050, SERIES 1	
FINISH		APPLICATION SPEC		SIZE	CAGE CODE
				D	00779
		WEIGHT		DRAWING NO	557103
				SCALE	4:1
				SHEET	2 OF 2