

Calmark offers the Series 101, 103, 104, 105 Card Extractors for efficient extraction of Printed Circuit Board from connectors and the Series 107 and 108 Card Inserter-Extractor for efficient insertion and extraction of Printed Circuit Board in high density connector contact and multiple connector applications.

FEATURES

- Lever action for safe easy card extraction
- Ample gripping and pushing surfaces for extracting and inserting card
- Available in colors for coding
- Generous area for hot stamp marking
- Exact replacement for other manufacturers

MATERIALS

Series 101, 103, 104, 105 molded in 6/6 Nylon. All Series 107 plastic extractors are molded in Glass Filled (30%) 6/6 or Type 6 Nylon. See table for flammability ratings. UL94-V0 parts are self extinguishing to flame. May be used at 121°C (250°F) continuously. Resistant to alkalis, weak acids, and common solvents.

ROLL PINS

- 2.38 (.094) dia x 6.35 (.250) long Series 101, 103, 104, 105, 107, 107-10, 107-20, 107-20-3, 107-70, 107-70-3
- 2.38 (.094) dia x 7.95 (.313) long Series 107-3, 107-10-3, 107-70-4
- 3.18 (.125) dia x 6.35 (.250) long Series 108
- 1.98 (.076) dia x 7.95 (.313) Series 107-30
- 2.38 (.094) dia x 12.7 (.500) long Series 107-40

COLOR

Other colors available see Part number code. Series 101, 103, 104, 105 standard color is natural/white. Series 107 and 108 standard color is black. For standard colors, a color suffix is not necessary.

HOT STAMPING

Hot stamp marking service is available. Please contact an Application Engineer with your requirements.

SERIES P - PRE-STARTED ASSEMBLY PIN

Calmark offers any of our extractors and inserter-extractors with the option of Pre-Started Assembly Pin.

FEATURES

- Faster and easier installation of extractor to PC card
- Eliminates need for special tools or equipment and set-up time
- Eliminates loss of loose assembly pins



Series 101 to 108 - Plastic Extractors

Series Part Number	Feature	Board Thickness	Standard Color	UL 94	Mechanical Advantage	Figures
101	E	1.6 (.063)	natural	V-2	3:1	1/A
V0101	E	1.6 (.063)	natural	V-0	3:1	1/A
103	E D	1.6 (.063)	natural	V-2	3:1	2/A
V0103	E	1.6 (.063)	natural	V-0	3:1	2/A
103-3	E D	2.4 (.093)	natural	V-2	3:1	2/A
V0103-3	E	2.4 (.093)	natural	V-0	3:1	2/A
104	E D	1.6 (.063)	natural	V-2	3:1	3/A
V0104	E	1.6 (.063)	natural	V-0	3:1	3/A
104-3	E D	2.4 (.093)	natural	V-2	3:1	3/A
V0104-3	E	2.4 (.093)	natural	V-0	3:1	3/A
105	E D	1.6 (.063)	natural	V-2	3:1	4/A or B
V0105	E	1.6 (.063)	natural	V-0	3:1	4/A or B
105-3	E D	2.4 (.093)	natural	V-2	3:1	4/A or B
V0105-3	E	2.4 (.093)	natural	V-0	3:1	4/A or B
107	I E D	1.6 (.063)	black	V-0	4.5:1	5/C
107-3	I E D	2.4 (.093)/3.2 (.125)	black	V-0	4.5:1	5/C
107-10	I E D	1.6 (.063)	black	V-0	3.3:1	6/C
107-10-3	I E D	2.4 (.093)	black	V-0	3.3:1	6/C
107-20	I E L	1.6 (.063)	black	V-2	4.5:1	7/D
V0107-20	I E L	1.6 (.063)	black	V-0	4.5:1	7/D
107-20-3	I E L	2.4 (.093)	black	V-0	4.5:1	7/D
V0107-20-3	I E L	2.4 (.093)	black	V-0	4.5:1	7/D
107-30	I E	1.6 (.063)	black	V-0	5.5:1	8/E
107-40	I E D	1.6 (.063)	black	V-0	4.5:1	9/C
107-40-3	I E	2.4 (.093)/2.4 (.125)	black	V-0	4.5:1	9/C
107-70	I E L	1.6 (.063)	black	V-0*	4.5:1	10/D
107-70-3	I E L	2.4 (.093)	black	V-0*	4.5:1	10/D
107-70-4	I E L	3.2 (.125)	black	V-0*	4.5:1	10/D
108	I E	1.6 (.063)	black	V-0	4.5:1	11/F

Feature: I = Inserter E = Extractor L = Latching D = meets DSCC 83023

For Pre-start pin feature, add "P" prefix to part number

*Main handle portion is UL-94V0, but latch is UL94-V2

For colors other than the standard color, use one of the following suffixes: BLK, BRN, RED, ORG, YEL, GRN, BLU, PRP, GRY or WHT.

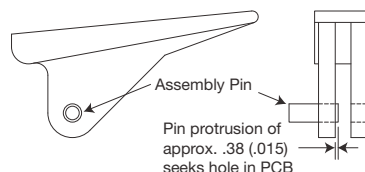

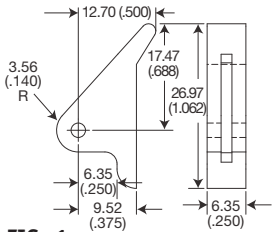

FIG. 1

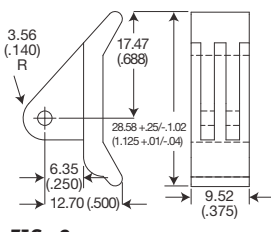

FIG. 2

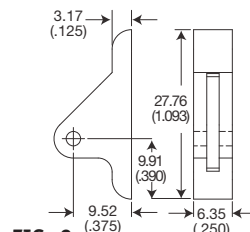

FIG. 3

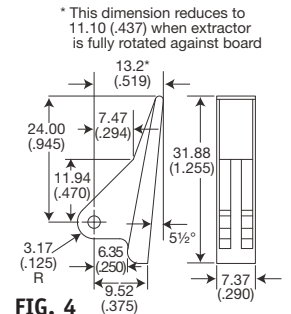

FIG. 4

* This dimension reduces to 11.10 (.437) when extractor is fully rotated against board

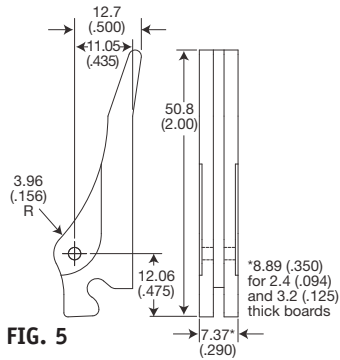

FIG. 5

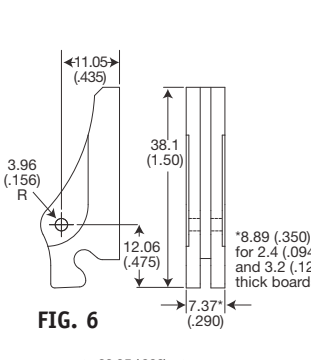

FIG. 6

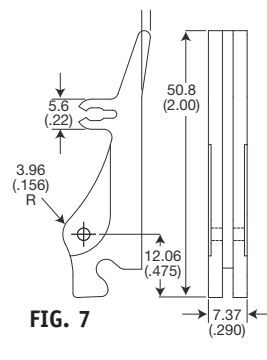

FIG. 7

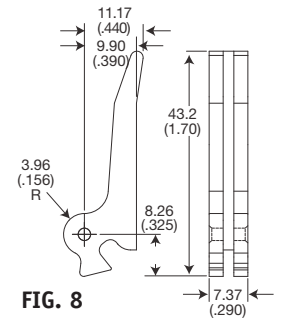

FIG. 8

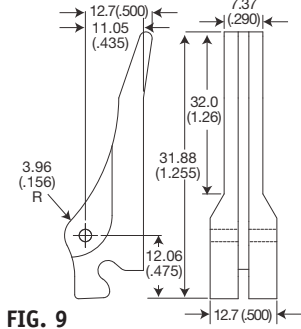

FIG. 9

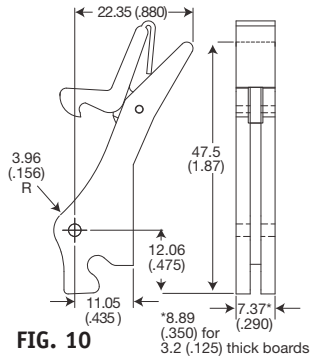

FIG. 10

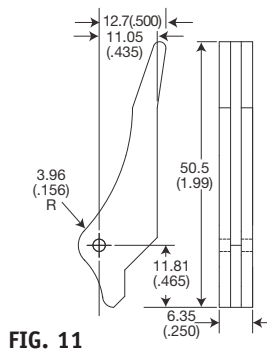

FIG. 11

Units: mm (in)
Unless specified otherwise,
.xx = ± .25, .x = ± .5
(.xxx = ± .010, .xx = ± .02)

APPLICATION DATA

Two inserter or inserter-extractors are recommended per printed circuit board taller than 127 (5) in height.

FIG. A

FIG. B

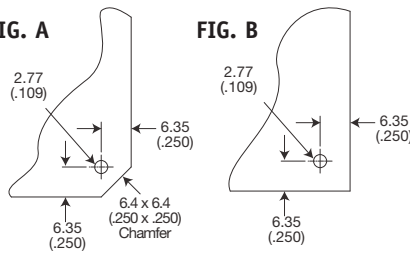

Provides insertion and extraction travel of 8.9 (.35) min.

Nominal position of card edge when seated in connector. The Inserter-Extractor will allow 1.3 (.05) overtravel for tolerance take-up.

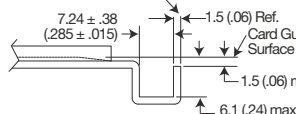

Detail of Actuating Surfaces
Required on Top and Bottom Guide Plates

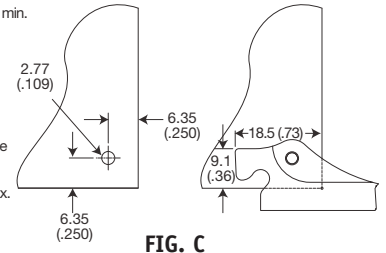
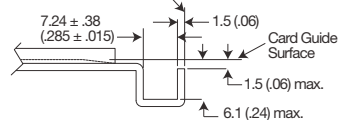

FIG. C

Provides insertion and extraction travel of 8.9 (.35) min.

Nominal position of card edge when seated in connector. The Inserter-Extractor will allow 1.3 (.05) overtravel for tolerance take-up.



Detail of Actuating Surfaces
Required on Top and Bottom Guide Plates

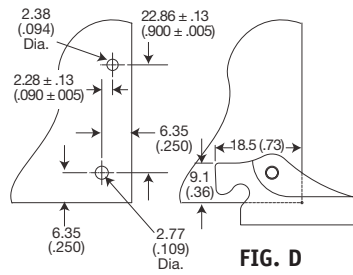
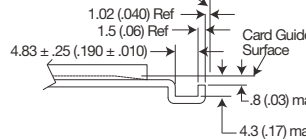

FIG. D

Provides insertion and extraction travel of 8.9 (.35) min.

Nominal position of card edge when seated in connector. The Inserter-Extractor will allow .8 (.03) overtravel for tolerance take-up.



Detail of Actuating Surfaces
Required on Top and Bottom Guide Plates

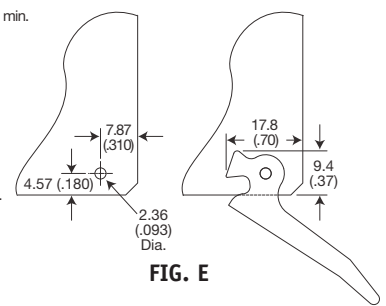

FIG. E

Provides insertion and extraction travel of 8.9 (.35) min.

Nominal position of card edge when seated in connector.

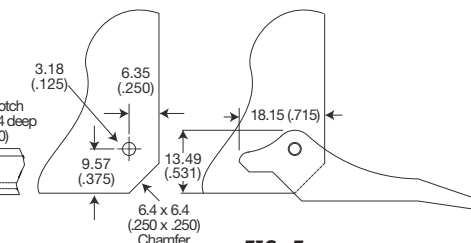
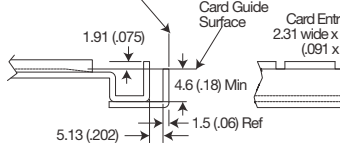

FIG. F

Units: mm (in)
Unless specified otherwise,
.xx = ± .25, .x = ± .5
(.xxx = ± .010, .xx = ± .02)